

低压IE5超高效永磁同步电机

Low Voltage IE5 Permanent Magnet Motors



目录 / Content

企业概述 / Company information	2
产品概述 General information.....	4
订购信息 / Ordering information.....	10
铭牌信息 / Rating plates	10
机械设计 / Mechanical design	11
电气特性 / Electrical design.....	16
变频器驱动 / Variable speed drives	17
技术数据 IE5 / Technical data IE5	19
变量代码 / Variant codes.....	27
外形图及外形尺寸 / Dimension drawings.....	33

企业介绍 / Corporate Introduction

企业介绍 / Corporate Introduction

萨尔茨自动化是集工业自动化产品、功能安全产品以及一体化工业自动化控制解决方案的研发、生产及成套调试等于一身的复合型供应商。公司旨在通过持续增强的全球合作伙伴网络及不断拓宽、优化的产品组合为世界各地的客户提供优质的服务。

公司总部设在德国美丽的温泉小镇Bad Salzuflen，距离全球知名的会展城市汉诺威仅40分钟车程。这里是萨尔茨自动化的创始人兼首席执行官托马斯·胡特梅尔的家乡，同时也是全球最知名的自动化公司的汇集地。公司的联合创始人托马斯·霍尔姆博士拥有自动化技术博士学位。他是控制系统和现代通信网络(如 TSN)领域的专家。

自公司成立以来，资深的全球团队通过25年与德国本土及全球知名的自动化公司合作，全面拥抱工业4.0带来的市场机遇及挑战，已成功开发完成自动化控制底层软件、功能性安全产品、基础元器件及电机等一系列软、硬件产品。具备完整的产品和工业工程的研究制造能力。公司同时密切追踪最新技术及市场发展趋势，根据研发路线图计划，全力拓展及优化产品组合，为客户提供更多增值服务。



Dr. Thomas Holm und Thomas Hüttemeier

SALZ Automation is an integrated provider that concentrates on providing the solutions of R&D, production, and the set of equipment's' commissioning for the industrial automation products, functional safety products, and integrated industrial automation. The company aims to supply high-quality services to worldwide customers through the comprehensive global-partners network, meanwhile expanding and optimizing the product- portfolios continuously.

The company is headquartered in the beautiful spa town of Bad Salzuflen in Germany, just 40-minute drive from the world-renowned exhibition city of Hanover. This is the hometown of Thomas Hüttemeier, the founder and CEO of Salz Automation, and the gathering place of the world's most well-known automation companies. Co-founder Dr. Thomas Holm has a doctorate in automation technology. He is an expert in the field of control systems and modern communication networks such as TSN.

Since its establishment, a senior global team has collaborated with well-known automation companies in Germany and around the world for 25 years, fully embracing the market opportunities and challenges brought by Industry 4.0. They have successfully developed a series of software and hardware products, including automation control underlying software, functional safety products, basic components, and motors. Having complete R&D and manufacturing capabilities in product and industrial engineering. The company closely tracks the latest technology and market development trends and strives to expand and optimize its product portfolio according to the R&D roadmap plan, providing customers with more value-added services.

企业介绍 / Corporate Introduction

我们的使命 / Our Mission

我们是挑战者，凭借深厚的知识和坚定的信念，我们帮助人们突破传统自动化的极限。

Combining forces to overcome the limits of industrial automation.

我们的价值观 / Our Value

- 追求具有高投资安全性的灵活解决方案
- 与客户形成伙伴关系
- 坚持高品质产品

- Pursuing flexible solutions with high investment security
- Achieving more through cooperation based on partnership
- We are working according to German quality standards

萨尔茨全球网络 / SALZ Global Network

萨尔茨自动化股份有限公司
总部位于德国巴特萨尔茨乌夫伦

SALZ Automation GmbH
Headquarters in Bad Salzufflen, Germany

萨尔茨自动化有限责任公司
位于美国佛罗里达

SALZ Automation, LLC
Located in Florida, U.S.

萨尔茨自动化（江苏）有限公司
位于中国苏州

SALZ Automation (Jiangsu) Co. Ltd.
Located in Changshu, China

萨尔茨电气（上海）有限公司
位于中国上海

SALZ Electric (Shanghai) Co., Ltd.
Located in Shanghai, China

产品概述 / General information

SALZSUE001系列永磁电机技术特性 / Features of SALZ SUE001

- | | |
|---|--|
| <ul style="list-style-type: none"> ● 机座材料：铸铁 ● 标准颜色：RAL7036 哑光 ● 额定功率：4~ 630 kW ● 效率达到IE5能效等级(TS IEC60034-30-2) ● 优化的紧凑结构设计，具有很高的功率密度 ● 标准安装结构类型(符合 IEC 60034-7 标准规定) ● 防护等级IP55 ● F级绝缘等级，B级温升 ● 标配国际品牌高品质轴承 | <ul style="list-style-type: none"> ● Frame material: Cast iron ● Standard color: RAL7036 Matt ● Rated power output: 4 ~ 630kW ● IE5 energy efficiency level (TS IEC60034-30-2) ● Optimized compact structure design with high power density ● Standard mounting construction according to IEC 60034-7 ● All motors are designed to IP55 degree of protection ● Insulation system is designed for Temperature class 155 (F). At rated output with line-fed operation, the motors can be used in temperature class 130 (B) ● Standard international brand high-quality bearings |
|---|--|

适用行业 / Target industry

SUE001系列采用稀土钕铁硼永磁材料，具有高效率、功率因数高、调速范围宽、启动力矩大、重量轻、低噪音等特点。此产品可广泛应用于暖通空调，水处理，食品饮料，纺织、冶金等行业的风机、泵类等多类型负载；同时为客户提供了更高的产品灵活性可满足各类客户的不同应用需求。

The SUE001 series uses Rare Earth NdFeB permanent magnet materials, which have the characteristics of high efficiency, high power factor, wide speed regulation range, large starting torque, light weight, and low noise. The motors can be widely used in various types of loads such as fans and pumps in industries such as HVAC, W&WW, Food and Beverage, textile, etc, and it provides customers with higher product flexibility to meet the different application needs of various customers.

运行环境 / Target industry

- | | |
|--|---|
| <ul style="list-style-type: none"> ● 防护等级 IP55 ● 高度不超过海拔 1000 m ● 环境空气温度：-20 °C ~ +40 °C ● 所允许的相对湿度： <ul style="list-style-type: none"> ○ -20 °C ≤ T ≤ 20 °C : 100 % ○ 20 °C < T ≤ 30 °C : 95 % ○ 30 °C < T ≤ 40 °C : 55 % | <ul style="list-style-type: none"> ● Degrees of motor protection IP55 ● Altitude shall not exceed 1000m ● Allowed air temperature between -20 °C and 40 °C ● Permitted relative humidity: <ul style="list-style-type: none"> ○ -20 °C ≤ T ≤ 20 °C : 100 % ○ 20 °C < T ≤ 30 °C : 95 % ○ 30 °C < T ≤ 40 °C : 55 % |
|--|---|

对于更高的环境温度、以及(或者)高于海拔1000m的地点，电动机的额定功率换算系数为 k_{HT} 。所允许的功率值(P_{adm})：

For higher coolant temperatures and / or site altitudes higher than 1000 m above sea level, the specified motor output must be reduced by using the factor k_{HT} . The results in an admissible output (P_{adm}) of the motor:

$$P_{adm} = P_{rated} \cdot k_{HT}$$

$$P_{adm} = P_{rated} \cdot k_{HT}$$

对于不同高度和(或)不同环境温度的功率换算系数 k_{HT}						
Factor k_{HT} for different site altitudes and / or coolant temperature						
海拔高度 Site altitude above sea level	对应海拔高度的环境温度 Site altitude above sea level coolant temperature					
	< 30°C	30 ~ 40°C	45°C	50°C	55°C	60°C
1000m	1.07	1.00	0.96	0.92	0.87	0.82
1500m	1.04	0.97	0.93	0.89	0.84	0.79
2000m	1.00	0.94	0.90	0.86	0.82	0.77
2500m	0.96	0.90	0.86	0.83	0.78	0.74
3000m	0.92	0.86	0.82	0.79	0.75	0.70
3500m	0.88	0.82	0.79	0.75	0.71	0.67
4000m	0.82	0.77	0.74	0.71	0.67	0.63

产品概述 / General information

噪声 / Noise levels

噪声值(直接供电运行)

噪声值根据 DIN EN ISO 1680 标准在噪音室测得。表面声压级噪声 L_{pfa} 计算表示单位为 dB (A)。声压级噪声的空间平均值是在其测量面上测得的。测量面是距离电动机表面一立方米的方。声功率级噪声用 L_{WA} 来表示，单位为 dB (A)。选型数据表中所给出的噪声值仅适用于全封闭自扇冷却(冷却方式：IC411)电动机在 50 Hz 电源供电空载运行时的情况，容差为 +3 dB。当在 60 Hz 电源下空载运行时，偏差值大约为 +4 dB。

Noise levels for mains-fed operation

The noise levels are measured in accordance with DIN EN ISO 1680 in a dead room. It is specified as the A-valued measuring-surface sound pressure level L_{pfa} in dB (A). This is the spatial mean value of the sound pressure levels measured on the measuring surface. The measuring surface is a cube 1 m away from the motor surface. The sound power level is also specified as L_{WA} in dB (A). The specified values in technical data table are only valid for totally enclosed fan cooling (cooling method: IC411) motor with no load at 50 Hz with no load, and the tolerance is +3 dB. While motor operating 60 Hz with no load, the values are approximately +4 dB (A) higher.

振动 / Vibration

所有电动机转子都使用半键按照 A 级(标准)振动等级进行动态平衡。
电动机在空载时测得振动速度有效值不超过下表中的 A 级所列值。

SUE rotors are dynamically balanced to severity grade A using a half key.
Table below contains the effective vibration values for unloaded motors.

振动等级 Vibration Grade	安装方式 Mounting	56mm≤H≤132		H > 132	
		位移/(um) Vibration displacement/ (μm)	速度/(mm/s) Vibration velocity/ (mm/s)	位移/(um) Vibration displacement/ (μm)	速度/(mm/s) Vibration velocity/ (mm/s)
A	自由悬置 Free suspension	45	2.8	45	2.8
	刚性安装 Rigid mounting	-	-	37	2.3 (2.8*)
B	自由悬置 Free suspension	18	1.1	29	1.8
	刚性安装 Rigid mounting	-	-	24	1.5 (1.8*)

冷却与通风 / Cooling and ventilation

标配装有径流(离心)式冷却风扇，其冷却效能与电动机的旋转方向无关(冷却方法符合 IEC60034-6 标准的 IC411)。

Standard motors are fitted with a radial flow fan for cooling in accordance with IC411 of IEC 60034-6.

对于某些应用，可以考虑配置独立驱动风扇，如：

- 电动机在低速运行时，推荐使用独立驱动风扇，从而使电动机得到有效利用
- 电动机在明显高于额定同步转速的速度运行时，同样推荐选用独立驱动风扇，这样有助于降低电动机噪声

For some special application, separately driven fan should be considered to be configured:

- The use of a separately driven fan is recommended to increase motor utilization at low speed
- When motor speed significantly higher than the synchronous speed, the separately fan is also recommended to be used. It can help reduce the motor noise

当安装独立驱动风扇时，电动机的长度将增加。

When the separately driven fan is mounted, the length of the motor will be increased.

产品概述 / General information

标准 / Standard



标准名称 Title	IEC 标准 IEC Standard	中国国家标准 Chinese standard
旋转电机 定额和性能 Rotating electrical machines - Part 1: Rating and performance	IEC60034-1	GB755
旋转电机尺寸和输出功率等级 Dimensions and output series for rotating electrical machines	IEC60072-1	GB/T4772.1
电动机能效限定值及能效等级 Energy efficiency and energy efficiency grades for three-phase motors	TS IEC60034-30-2	GB30253-2013
标准电压 IEC standard voltages	IEC60038	GB/T156
旋转电机线端标志与旋转方向 Rotating electrical machines - Part 8: Terminal markings and direction of rotation	IEC60034-8	GB/T1971
中小型旋转电机安全通用要求 General requirements for safety of small and medium size rotating electrical machines		GB/T14711
电工电子产品环境试验 Environmental testing	IEC60068	GB/T2423
旋转电机的防护等级 (IP) 分级 Rotating electrical machines - Part 5: Degrees of protection provided by the integral design of rotating electrical machines (IP code); Classification	IEC60034-5	GB/T4942.1
旋转电机噪声限值 Rotating electrical machines - Part 9: Noise limits	IEC60034-9	GB/T10069.3
旋转电机冷却方法 Rotating electrical machines; part 6: methods of cooling (IC code)	IEC60034-6	GB/T1993
电机结构及安装型式代号 Rotating electrical machines; part 7: classification of types of constructions and mounting arrangements (IM code)	IEC60034-7	GB/T997
轴中心高为 56mm 及以上电动机的机械振动振动的测量、评定及限值 Rotating electrical machines - Part 14: Mechanical vibration of certain machines with shaft heights 56 mm and higher; Measurement, evaluation and limits of vibration severity	IEC60034-14	GB10068

产品概述 / General information

对比异步电机，永磁同步电机在低频范围拥有更高的效率及功率因数。

Compared to General Motors, permanent magnet motors have higher efficiency and power factor in the low frequency range.

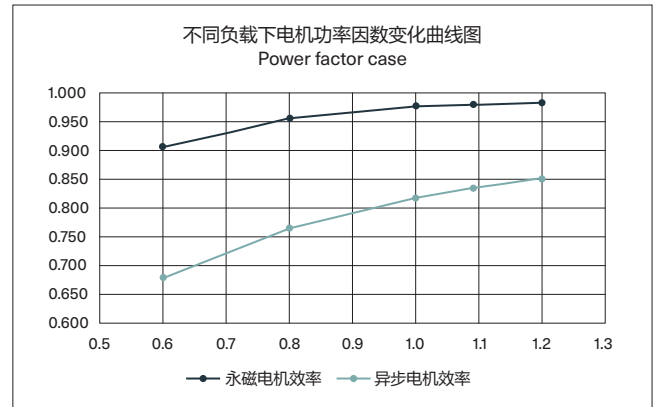
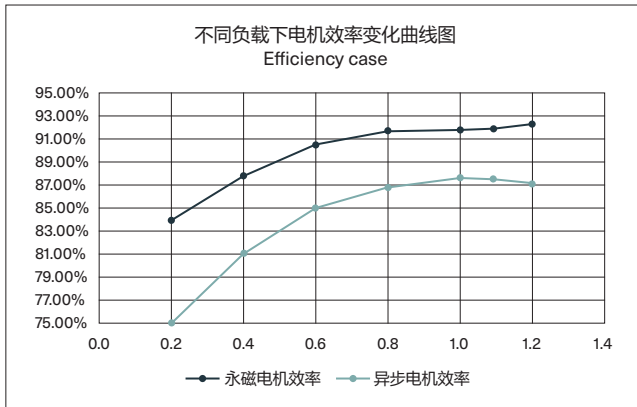

以 160kW 永磁同步电机为例：

效率 $\eta = 97.2\%$

输入功率： $P_1 = P_2 / \eta = 160\text{kW} / 97.2\% = 164.61\text{kW}$

160kW permanent magnet motor as an example:

Efficiency $\eta = 97.2\%$

Input Power: $P_1 = P_2 / \eta = 160\text{kW} / 97.2\% = 164.61\text{kW}$

普通效率电动机：

效率 $\eta = 94.9\%$

输入功率： $P_1 = P_2 / \eta = 160\text{kW} / 94.9\% = 168.60\text{kW}$

General Motor:

Efficiency $\eta = 94.9\%$

Input Power: $P_1 = P_2 / \eta = 160\text{kW} / 94.9\% = 168.60\text{kW}$

年运行成本：年运行成本 = 输入功率 x 运行时间 x 电价

Cost = Input Power x Operating Time x Electricity Price

年节约电费：年节约电费 = $(168.60 - 164.61) \times 8,760 \times 1 \approx 34,952.4$ 元

Cost savings : Cost savings = $(168.60 - 164.61) \times 8,760 \times 1 \approx 34,952.4$ CNY

(以电机的年工作时间8760小时均为满负载状态下工作，电价 1元 /kWh 计算)

(Based on the annual working time is 8760 hours and operates at full load, with an electricity price of 1 CNY/kWh)

产品概述 / General information

设计仿真 / Design simulation

效率MAP仿真

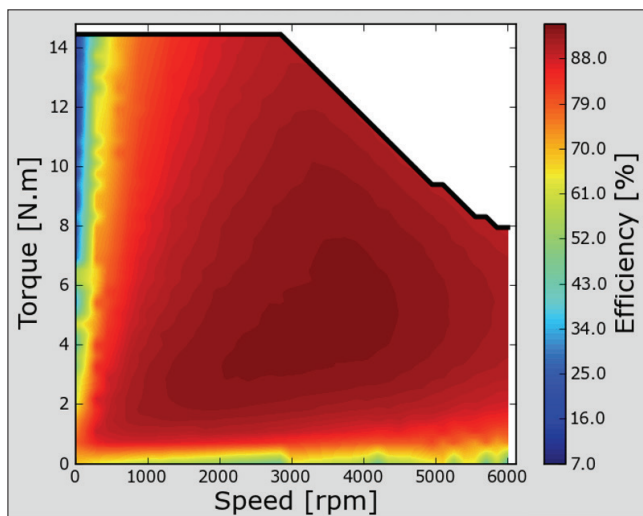

轴挠度仿真

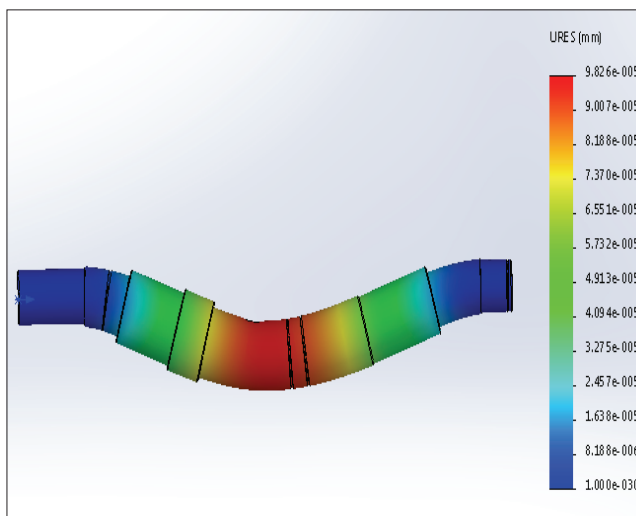

电磁场仿真

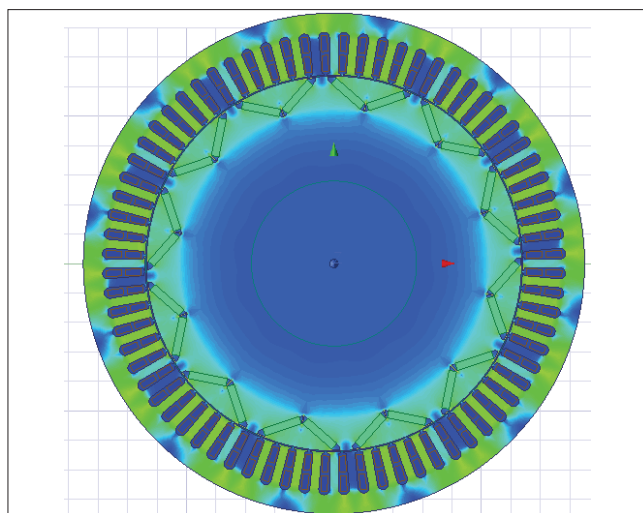

冲片强度仿真

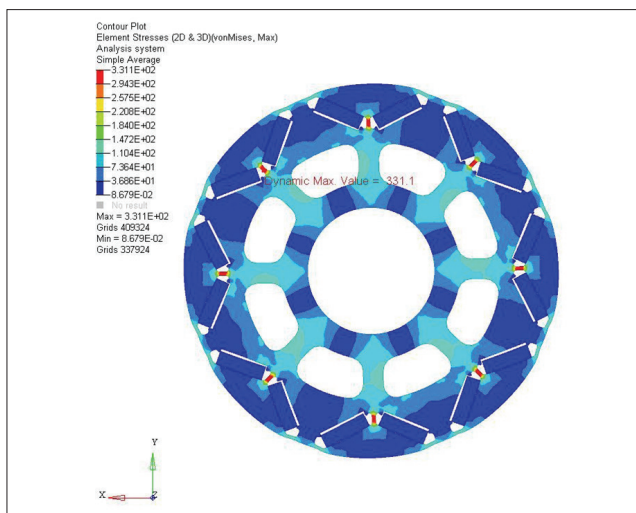

热仿真

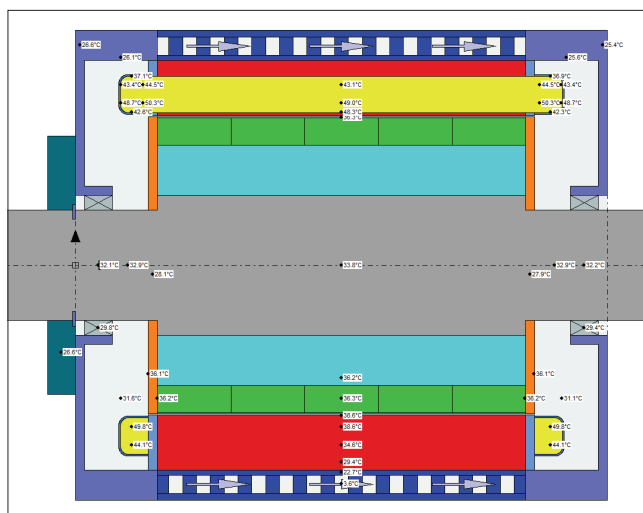

产品概述 / General information

安装结构形式 / Mounting arrangements

底脚安装型电机

Foot-mounted motor



IM B3	IM V5	IM V6	IM B6	IM B7	IM B8
IM 1001	IM 1011	IM 1031	IM 1051	IM 1061	IM 1071

凸缘安装型电机，大凸缘

Flange-mounted motor, large flange



IM B5	IM V1	IM V3	(*)	(*)	(*)
IM 3001	IM 3011	IM 3031	IM 3051	IM 3061	IM 3071

凸缘安装型电机，小凸缘

Flange-mounted motor, small flange



IM B14	IM V18	IM V19	(*)	(*)	(*)
IM 3601	IM 3611	IM 3631	IM 3651	IM 3661	IM 3671

底脚和凸缘安装型电机，大凸缘

Foot- and flange-mounted motor with feet, large flange



IM B35	IM V15	IM V35	(*)	(*)	(*)
IM 2001	IM 2011	IM 2031	IM 2051	IM 2061	IM 2071

底脚和凸缘安装型电机，小凸缘

Foot- and flange-mounted motor with feet, small flange



IM B34	IM V17				
IM 2101	IM 2111	IM 2131	IM 2151	IM 2161	IM 2171

(*) IEC 60034-7 无规定。

Not Stated in IEC 60034-7.

订购信息 / Ordering information

型号命名规则 / Model naming convention

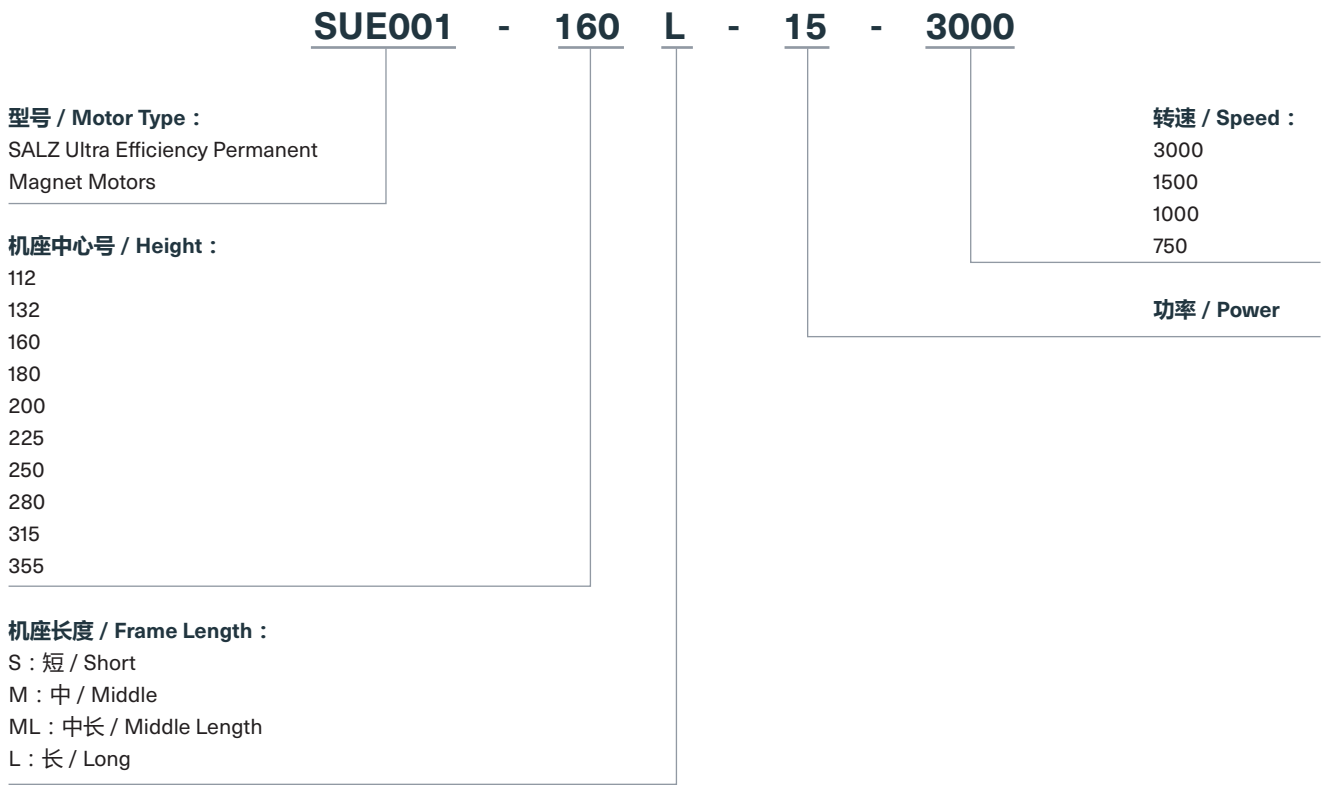

铭牌信息 / Rating plates

铭牌以表格形式提供标准电压的转速、电流和功率因数的数值。

The rating plates are in table form giving values for speed current and power factor for standard voltages.

SALZ		IE5			
3~Motor SUE001-160M-11-1500		TS IEC 60034-30-2			
No:		IM B3	Ins. Cl F	IP55	
V	Hz	KW	A	r/min	cosØ
380Y	100	18.5	19.6	1500	0.96
IE5-93.8%		CONVERTER DUTY ONLY			
6309-2Z/C3	6309-2Z/C3	151 kg	Date: 2024.01		
THREE PHASE PERMANENT MAGENT MOTOR					

说明：铭牌图片仅供格式参考，最终数据以实际铭牌为准。

Remark: The format of the rating plate is for reference only. The final figure will be subject to the actual rating plate.

机械设计 / Mechanical design

接线盒 / Terminal box

SALZ SUE001系列永磁同步电机标准设计接线盒位于电动机顶端，可4x90°旋转安装，使电缆可以从各个方向引入(部分规格旋转90°后可能会与吊环或前方设备相干涉)，所有接线盒配1~2个塑料电缆密封管，接线盒内部安装接地保护装置，标准接线盒的防护等级为 IP55。

The terminal box is located on the top of motor housing as standard, and can be rotated by 4x90° to allow for cable entry from each direction. The terminal box has 1~2 main cable entries. Earthing in main terminal box. The degree of protection for the standard terminal box is IP 55.

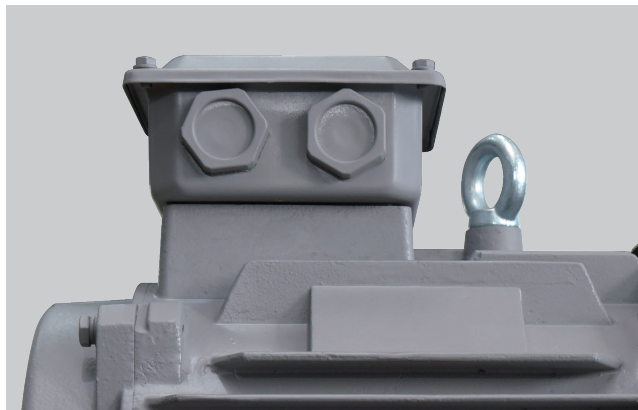

接线盒的位置 / Location of the terminal box

接线盒除标准位置外，还可处于电动机的左侧或右侧。电动机接线盒位置可在变量代码中用字符和数字标示出。

Besides standard position, the terminal box also can be on the right or left of motor housing. The position of terminal box can be indicated with digit of motor variant code.

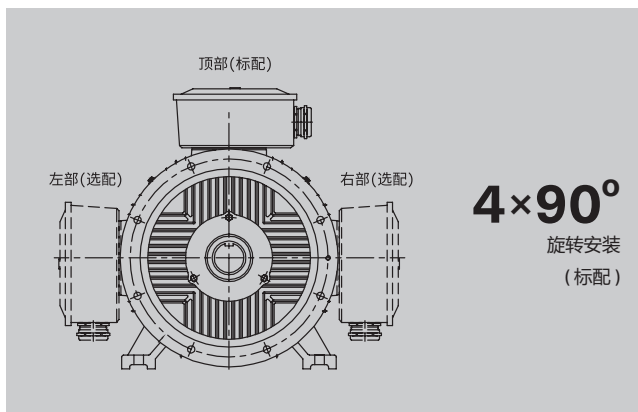

塑料电缆密封管 / Plastic cable sealing pipe

SALZ SUE系列通用电机接线盒标配 2-3 个塑料电缆密封管。塑料电缆密封管尺寸请参照下表：

The terminal box of SUE series motor have 2~3 main cable entries , all cable entries see the below table:

机座号 Motor Size	主进线孔尺寸(电缆密封管 + 螺塞) Threaded holes	适合电缆外径(mm) Cable outer diameter (mm)
112~132	2 - M25 x 1.5	13 - 18
160~180	2 - M40 x 1.5	22 - 32
200~225	2 - M50 x 1.5	32 - 38
250~315	2 - M63 x 1.5	37 - 44
355	2 - M72 x 2	42 - 50

如果电机带绕组元件，接线盒会增加一个M16x1.5的塑料电缆密封管，适合电缆外径4-8mm。

如有其它特殊要求，请参考变量代码。

If the motor is equipped with winding components, an M16x1.5 plastic cable sealing tube will be added to the terminal box, suitable for cable outer diameter of 4-8mm. If there are other special requirements, please refer to the variant code.

机械设计 / Mechanical design

轴承 / Bearings

SALZ SUE系列通用电机全系标配进口品牌轴承。80~160机座标配密封式深沟球轴承；180~355机座标配可润滑深沟球轴承或角接触球轴承，也可选装密封式轴承。如需增强驱动端悬臂力，160~355机座轴伸端可配圆柱轴承。轴承配置见下表，轴承润滑及维护详见电动机使用维护说明书。

The SALZ SUE series motors are equipped with imported brand bearings as standard. The 80-160 with sealed deep groove ball bearings; The 180-355 with lubricated deep groove ball bearings or angular contact ball bearings, and can also be equipped with sealed bearings. If it is necessary to enhance the cantilever force at the driving end, cylindrical bearings can be equipped at the shaft extension end of the 160-355. The bearing configuration is shown in the table below, and the lubrication and maintenance of the bearings are detailed in the motor maintenance manual.

机座号 Motor size	转速 Speed	轴承 Bearings	
		驱动端、水平安装 D-end	非驱动端 N-end
112	750/1000/1500/3000	6306-2Z/C3	6306-2Z/C3
132	750/1000/1500/3000	6308-2Z/C3	6308-2Z/C3
160	750/1000/1500/3000	6309-2Z/C3	6309-2Z/C3
180	750/1000/1500/3000	6311/C3	6311/C3
200	750/1000/1500/3000	6312/C3	6312/C3
225	750/1000/1500/3000	6313/C3	6312/C3
250	750/1000/1500/3000	6314/C3	6313/C3
280	3000	6314/C3	6313/C3
280	750/1000/1500	6317/C3	6314/C3
315	3000	6317/C3	6317/C3
315	750/1000/1500	6319/C3	6319/C3
355	3000	6319/C3	6319/C3
355	750/1000/1500	6322/C3	6322/C3

1. 如需专用轴承，需提供轴承所需要承受的轴向力的大小和方向。
2. 标准永磁同步电机已包含变频驱动下的耐电流腐蚀处理，也选用绝缘轴承，参考变量代码。

1. If a dedicated bearing is required, please provide the magnitude and direction of the axial force that the bearing needs to withstand.
2. The standard permanent magnet motor already includes current corrosion resistance treatment under variable frequency drive, and insulated bearings are also selected, with reference to variable code.

机械设计 / Mechanical design

轴承寿命 / Bearing life

根据 ISO 281, 轴承的正常寿命 L_{10h} 定义为在特定条件下 90% 的相同轴承在一系列测试中所达到或超过的运行小时数。50% 的轴承至少达到这一数字的五倍。

The nominal life L_{10h} of a bearing is defined according to ISO 281 as the number of operating hours achieved or exceeded by 90% of identical bearings in a large test series under specified conditions. 50% of bearings achieve at least five times this lifetime.

润滑 / Lubrication

在变速应用场合中, 轴承温度的变化是由于速度和电机负载变化的结果。这时, 在正常工作条件下, 通过测量轴承温度, 可以得到最精确的润滑间隔时间。如果测量温度高于 +80°C, 则需要缩短在润滑铭牌或电机手册中规定的润滑间隔时间, 或使用适用于高温工况的润滑脂。在非常低的速度和温度(低于 20°C)下连续工作时, 标准润滑脂的润滑能力可能不足, 而需要使用含添加剂的特定润滑脂。如果电机配备密封轴承, 即一次性润滑轴承, 则务必注意, 当工作温度与设计温度不同时, 轴承的工作寿命也会与设计值不同。

In variable speed applications, bearing temperature varies as a function of speed and motor load. In such cases, the most accurate relubrication intervals can be obtained by measuring the bearing temperature under normal operating conditions. If the measured temperature is higher than +80°C, the relubrication intervals specified on the lubrication plate or in the maintenance manual must be shortened, or lubricants suitable for high operating temperatures must be used.

In case of continuous operation at very low speeds and at very low temperatures (below -20°C), the lubrication properties of standard greases may not be sufficient, and special greases with additives are needed. Operating temperatures also affect bearing life. When motors are equipped with sealed bearings, that is, bearings greased for life, it must be noted that if the operating temperature differs from the design temperature, the bearing life will also be different.

皮带轮直径 / Pulley diameter

所需轴承寿命确定后, 最小允许皮带轮直径可使用 F_R 计算, 如下所示:

$$D = \frac{1.9 \cdot 10^7 \cdot K \cdot P}{n \cdot F_R}$$

其中:

- D: 带轮直径, 单位(mm)
- P: 功率要求, kW
- n: 电机转速, r/min
- K: 皮带张力因数, 取决于皮带类型和负载类型。
- V形皮带通用值为 2.5
- F_R : 允许径向力

When the desired bearing life has been determined, the minimum permissible pulley diameter can be calculated with F_R as follows:

$$D = \frac{1.9 \cdot 10^7 \cdot K \cdot P}{n \cdot F_R}$$

Where:

- D: Pulley diameter, mm
- P: Power requirement, kW
- n: Motor speed, r/min
- K: Belt tension factor, dependent on belt type and type of duty
- A common value of V-belts is 2.5
- F_R : Permissible radial force

机械设计 / Mechanical design

轴上允许负载 / Permissible loading on the shaft

允许径向力

表中提供了环境温度为25°C时，正常条件下，轴向力为零时的轴伸允许径向力(N)。分别对轴承寿命满足20,000小时和40,000小时进行计算。

电机为底座安装型IM B3，并且含横向力。在某些情况下，轴的强度影响允许负载力。需提供同时存在径向力和轴向力的允许负载值，请联系SALZ。

如果径向力作用于点 X_0 和 X_{max} 之间，则允许负载力 F_R 可以通过以下公式计算：

$$F_R = F_{X_0} - \frac{X}{E} (F_{X_0} - F_{X_{max}})$$

E：基本型号中的轴伸长度。

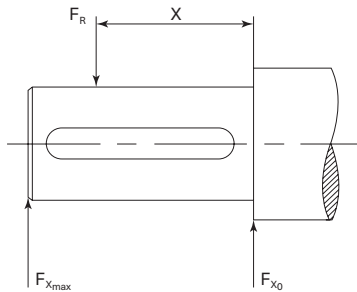

Permissible radial forces

The following table gives the permissible radial forces on shaft in Newton, assuming zero axial force, ambient temperature of 25°C, and normal conditions at 50Hz. The values are given for calculated bearing life of 20,000 and 40,000 hours per motor size.

These calculated values further assume mounting position IM B3 (foot-mounted), with force directed sideways. In some cases, the strength of the shaft affects permissible forces. Permissible loads of simultaneous radial and axial forces can be supplied on request.

If the radial force is applied between points X_0 and X_{max} , the permissible force F_R can be calculated with the following formula:

$$F_R = F_{X_0} - \frac{X}{E} (F_{X_0} - F_{X_{max}})$$

E：Length of the shaft extension in the standard version.

标准机座 / IEC Frame Size

机座号 Motor Size	轴伸允许的最大径向力 (N) - 20000h (L10h) The permissible axial forces on shaft in Newton (N)							
	3000rpm		1500rpm		1000rpm		750rpm	
	F_{X_0}	$F_{X_{max}}$	F_{X_0}	$F_{X_{max}}$	F_{X_0}	$F_{X_{max}}$	F_{X_0}	$F_{X_{max}}$
112M	1399	1130	1761	1422	-	-	-	-
132S	2140	1674	2692	2105	-	-	-	-
132M	-	-	2727	2191	3124	2510	-	-
160M	2747	2127	3452	2673	3953	3061	4358	3374
160L	2774	2200	3479	2759	3987	3162	4394	3484
180M	3805	3041	4786	3826	-	-	-	-
180L	-	-	4814	3910	5520	4484	6076	4936
200L	4325	3565	5433	4479	6233	5138	6869	5662
225S	-	-	6121	4815	-	-	7735	6084
225M	4607	3834	6105	4802	7007	5511	7715	6069
250M	5430	4416	6824	5549	7836	6372	8631	7018
280S	7002	5774	8825	7277	10087	8318	11105	9157
280M	5494	4588	8890	7424	10160	8485	11180	9336
315S	6696	5733	10063	8306	11560	9541	12748	10522
315ML	6698	5832	10027	8453	11549	9737	12717	10722
355ML	7221	6431	12852	11146	15007	13015	16589	14386

机械设计 / Mechanical design

标准机座 / IEC Frame Size

机座号 Motor Size	轴伸允许的最大径向力 (N) - 40000h (L10h) The permissible axial forces on shaft in Newton (N)							
	3000rpm		1500rpm		1000rpm		750rpm	
	F_{x0}	F_{xmax}	F_{x0}	F_{xmax}	F_{x0}	F_{xmax}	F_{x0}	F_{xmax}
112M	1109	895	1395	1127	-	-	-	-
132S	1695	1325	2131	1666	-	-	-	-
132M	-	-	2158	1734	2473	1987	-	-
160M	2177	1686	2733	2117	3130	2424	3452	2673
160L	2195	1741	2750	2181	3152	2500	3475	2756
180M	3013	2408	3788	3028	-	-	-	-
180L	-	-	3806	3092	4367	3547	4807	3905
200L	3421	2820	4294	3540	4929	4063	5433	4479
225S	-	-	4836	3804	-	-	6115	4810
225M	3643	3032	4820	3791	5535	4354	6096	4795
250M	4284	3484	5381	4376	6184	5029	6813	5540
280S	5543	4570	6986	5761	7983	6582	8788	7247
280M	4343	3627	7036	5876	8038	6712	8844	7386
315S	5280	4521	7935	6549	9123	7530	10067	8309
315ML	5257	4578	7870	6635	9080	7656	10000	8431
355ML	5536	4931	9932	8614	11665	10116	12910	11196

缩小机座 / Non IEC Frame Size

机座号 Motor Size	轴伸允许的最大径向力 (N) - 20000h (L10h) The permissible axial forces on shaft in Newton (N)							
	3000rpm		1500rpm		1000rpm		750rpm	
	F_{x0}	F_{xmax}	F_{x0}	F_{xmax}	F_{x0}	F_{xmax}	F_{x0}	F_{xmax}
112M	1397	1128	1760	1421	-	-	-	-
132M	-	-	2727	2191	3124	2510	-	-
160M	2731	2115	3448	2670	3949	3058	4354	3372
160L	-	-	3453	2738	3955	3137	4378	3472
180M	3755	3001	4719	3772	5425	4336	5988	4786
200L	4228	3485	5359	4418	6159	5076	6787	5594
250M	5321	4327	6744	5484	7769	6318	8567	6967
280S	5263	4339	-	-	9888	8153	10894	8983
280M	5056	4223	8506	7103	9712	8110	10709	8943
280ML	4794	4064	8095	6862	9217	7813	10183	8632
315ML	5996	5222	9274	7821	10627	8962	11828	9975
355ML	6499	5789	12074	10472	13864	12025	15636	13562

机座号 Motor Size	轴伸允许的最大径向力 (N) - 40000h (L10h) The permissible axial forces on shaft in Newton (N)							
	3000rpm		1500rpm		1000rpm		750rpm	
	F_{x0}	F_{xmax}	F_{x0}	F_{xmax}	F_{x0}	F_{xmax}	F_{x0}	F_{xmax}
112M	1107	894	1394	1126	-	-	-	-
132M	-	-	2158	1734	2473	1987	-	-
160M	2161	1673	2729	2114	3126	2421	3449	2670
160L	-	-	2724	2160	3121	2475	3460	2744
180M	2963	2368	3721	2974	4283	3423	4731	3781
200L	3324	2740	4220	3479	4854	4001	5351	4411
250M	4176	3396	5301	4311	6117	4975	6749	5488
280S	4121	3398	-	-	7783	6418	8577	7072
280M	3906	3262	6652	5555	7590	6338	8373	6993
280ML	3682	3121	6303	5342	7165	6074	7925	6717
315ML	4563	3974	7130	6012	8171	6891	9125	7696
355ML	4810	4285	9145	7932	10511	9117	11946	10361

电气特性 / Electrical design

运行环境 / Environmental

根据 IEC 60034-1 规定，容差是指测试值与铭牌(或样本)标称值之间的最大允许偏差。测试结果基于按照 IEC 60034-2-1, IEC60034-9, IEC 60034-12 所规定的测试。

In accordance with IEC 60034-1, tolerance is the maximum allowed deviation between the test result and the declared value on the rating plate (or in the catalog). Test results are based on test procedures in accordance with IEC 60034-2-1, IEC 60034-9, and IEC 60034-12.

绝缘系统 / Insulation system

SALZ采用 F 级绝缘材料，B 级温升设计。

F级绝缘系统B级温升的采用，使SALZ产品可获得25°C的安全裕度。这使电机在短时间内过载使用，或在较高环境温度和海拔，或在高电压和频率容差下使用成为可能。这一设计同样可用于延长绝缘寿命。例如，温度降低10K，绝缘寿命延长。

B 级绝缘(130°C)：

- 额定环境温度 40°C
- 最大允许温升 80K
- 热点温升裕度 10K

F 级绝缘(155°C)：

- 额定环境温度 40°C
- 最大允许温升 105K
- 热点温升裕度 10K

H 级绝缘(180°C)：

- 额定环境温度 40°C
- 最大允许温升 125K
- 热点温升裕度 10K

SALZ uses class F insulation, which with temperature rise B, is the common requirement among industry today. The use of class F insulation with class B temperature rise gives SALZ products a 25°C safety margin. This can be used to increase the loading for limited periods, to operate at higher ambient temperatures or altitudes, or with greater voltage and frequency tolerances. It can also be used to extend insulation life. For instance, a 10 K temperature reduction will extend the insulation life.

Thermal class 130 (B):

- Nominal ambient temperature 40°C
- Max permissible temperature rise 80K
- Hot spot temperature margin 10K

Thermal class 155 (F):

- Nominal ambient temperature 40°C
- Max permissible temperature rise 105K
- Hot spot temperature margin 10K

Thermal class 180 (H):

- Nominal ambient temperature 40°C
- Max permissible temperature rise 125K
- Hot spot temperature margin 15K

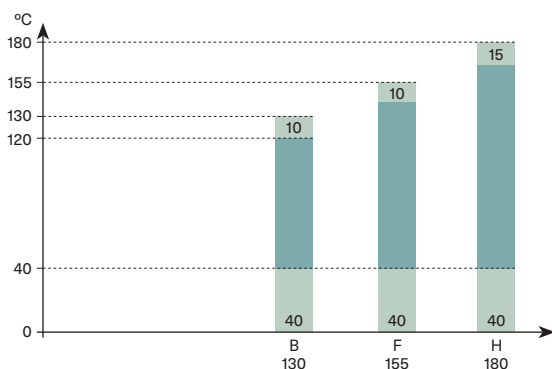

各绝缘等级的安全裕度
Safety margins per thermal class

变频器驱动 / Variable speed drives

绕组绝缘 / Winding insulation

为确保电机的可靠性，当为电机选择正确的绝缘系统和为变频器选择正确的输出滤波器时，必须考虑变频器的非正弦输出电压的影响。

当使用具有非受控直流电压的变频器时，应根据下表选择绝缘和滤波器。

下表变频器(其具有非受控直流电压)电机的绕组绝缘及变频器输出滤波器选择。

To ensure that motors operate reliably, the effects of non-sinusoidal output voltages from the converter must be taken into consideration when selecting the correct insulation system for the motor and output filters for the converter. Insulation and filters must be selected according to table below.

Selection of motor winding insulation and converter output filters.

所要求的绕组绝缘和滤波器

Winding insulation and filters required

500V < UN ≤ 600V

变频绝缘 +dU/dt 滤波器或变频加强绝缘

VSD insulation + dU/dt filters OR VSD reinforced insulation

600V < UN ≤ 690V

变频加强绝缘及变频器输出端的dU/dt 滤波器

VSD reinforced insulation AND dU/dt filters at converter output

轴承电流 / Bearing currents

必须在所有电机中消除轴承电压和电流，确保整项工作的可靠开展。如果使用具有非受控直流电压的驱动器，则必须按照下表所示，使用绝缘轴承和/或在变频器输出上加上适当规格的滤波器。

下表与变频器(其具有非受控直流电压)配合使用的电机中的轴承电流防护。

Bearing voltages and currents must be avoided in all motors to ensure reliable operation of the entire application. With drives and uncontrolled DC voltage, insulated bearings and/or properly dimensioned filters at the converter must be used, as indicated in table below.

Precautionary measures to avoid bearing currents in variable speed drives.

功率(P_N)及/或机座号

Output (P_N) AND / OR Motor size

P_N ≤ 100 kW

防护措施

Precautionary measures

无需采取措施

No action needed

P_N ≥ 100 kW

非驱动端绝缘轴承

Insulated non-drive end bearing

P_N ≥ 350 kW

非驱动端绝缘轴承，在变频器中设置共模滤波器

Insulated non-drive end bearing AND Common mode filter at the converter

变频器驱动 / Variable speed drives

共模滤波器 / Common mode filters

共模滤波器减少了共模电流，从而减少了出现轴承电流的风险。共模滤波器不会严重影响电机接线端子的相电压或电源电压。

Common mode filters reduce common mode currents and so decrease the risk of bearing currents. Common mode filters do not significantly affect the phase of main voltages on motor terminals.

绝缘轴承 / Insulated bearings

SALZ使用带绝缘内圈或外圈的轴承。所谓混合轴承，也就是带非导电性陶瓷滚动元件的轴承，也可用于特定用途。

SALZ uses bearings with insulated inner or outer races. Hybrid bearings, that is, bearings with non-conductive ceramic rolling elements, can also be used in special applications.

电缆敷设、接地及EMC / Cabling, grounding, and EMC

变频器对驱动系统的电缆铺设和接地提出了更高的要求。应使用屏蔽对称电缆和提供360°接头的电缆接头(也称为EMC接头)来连接电机。对于输出功率不高于30kW的电机，可使用非对称电缆，但使始终建议使用屏蔽电缆，尤其在驱动应用中存在敏感部件时。

对于机座号为IEC 250及以上的电机，除非在一个公共的金属底座上安装电机和驱动机器，否则需要在电机机座和机器之间另外进行电位均衡处理。当使用一个金属底座来实现电位均衡时，应检查此连接的高频导电性。

The use of a variable speed drive sets higher demands on the cabling and grounding of the drive system. The motor must be cabled using shielded symmetrical cables and cable glands providing 360° bonding (EMC glands). For motors up to 30 kW, asymmetrical cables can be used, but shielded cables are always recommended, especially if there are sensitive components in the driven application. For motor sizes IEC 250 and above, additional potential equalization is needed between the motor frame and the machinery, unless the motor and the driven machine are installed on a common steel base. When a steel base is used for potential equalization, high frequency conductivity of the connection must be checked.

IP55 - IC411 - 绝缘等级F, 温升等级B
 IE5效率等级数据根据 IEC 60034-30-2:2016
 标准机座: 同步转速 3000rpm 380V

IP55 - IC411 - Insulation class F, temperature class B
 IE5 according to IEC 60034-30-2:2016
 Standard Frame: Speed 3000rpm 380V

功率 Output	型号规格 Motor Type	额定转速 Speed	效率(100%) Efficiency 100%	功率因数 Power factor	额定电流 Current	额定转矩 Torque	频率 Frequency	转动惯量 Moment of inertia J = 1/4	重量 Weight
kW		r/min		cos ϕ	I _N A	T _N Nm	Hz	GD ² kgm ²	kg
4	SUE001-112M-4-3000	3000	93.3%	0.96	7.16	12.7	150	0.000819	32
5.5	SUE001-132S-5.5-3000	3000	94.0%	0.96	9.77	17.5	150	0.00192	47
7.5	SUE001-132S-7.5-3000	3000	94.5%	0.96	13.3	23.9	150	0.00288	53
11	SUE001-160M-11-3000	3000	95.0%	0.96	19.3	35.0	200	0.00441	138
15	SUE001-160M-15-3000	3000	95.3%	0.96	26.3	47.8	200	0.00589	143
18.5	SUE001-160L-18.5-3000	3000	95.6%	0.96	32.3	58.9	200	0.00737	153
22	SUE001-180M-22-3000	3000	95.9%	0.96	38.3	70.0	200	0.00932	143
30	SUE001-200L-30-3000	3000	96.1%	0.96	52.2	95.5	200	0.0176	154
37	SUE001-200L-37-3000	3000	96.3%	0.96	64.2	118	200	0.0235	161
45	SUE001-225M-45-3000	3000	96.4%	0.96	78.0	143	200	0.0265	210
55	SUE001-250M-55-3000	3000	96.5%	0.96	95.2	175	200	0.0565	351
75	SUE001-280S-75-3000	3000	96.6%	0.96	130	239	200	0.0818	370
90	SUE001-280M-90-3000	3000	96.7%	0.96	155	287	200	0.105	392
110	SUE001-315S-110-3000	3000	96.8%	0.96	190	350	200	0.284	621
132	SUE001-315ML-132-3000	3000	96.9%	0.96	228	420	200	0.355	660
160	SUE001-315ML-160-3000	3000	97.0%	0.96	276	509	200	0.425	683
200	SUE001-315ML-200-3000	3000	97.2%	0.96	344	637	200	0.532	722
250	SUE001-355ML-250-3000	3000	97.2%	0.96	430	796	200	0.908	1040
280	SUE001-355ML-280-3000	3000	97.2%	0.96	481	891	200	1.03	1074
315	SUE001-355ML-315-3000	3000	97.2%	0.96	541	1003	200	1.15	1109
355	SUE001-355ML-355-3000	3000	97.2%	0.96	610	1130	200	1.27	1143
400	SUE001-355ML-400-3000	3000	97.2%	0.96	687	1273	200	1.45	1195
450	SUE001-355ML-450-3000	3000	97.2%	0.96	773	1433	200	1.64	1247
500	SUE001-355ML-500-3000	3000	97.2%	0.96	859	1592	200	1.82	1298
560	SUE001-355ML-560-3000	3000	97.2%	0.96	962	1783	200	2.12	1384
630	SUE001-355ML-630-3000	3000	97.2%	0.96	1083	2006	200	2.42	1470

IP55 - IC411 - 绝缘等级F, 温升等级B

IE5效率等级数据根据 IEC 60034-30-2:2016

标准机座: 同步转速 1500rpm 380V

IP55 - IC411 - Insulation class F, temperature class B

IE5 according to IEC 60034-30-2:2016

Standard Frame: Speed 1500rpm 380V

功率 Output	型号规格 Motor Type	额定转速 Speed	效率(100%) Efficiency 100%	功率因数 Power factor	额定电流 Current	额定转矩 Torque	频率 Frequency	转动惯量 Moment of inertia J = 1/4	重量 Weight
kW		r/min		cos ϕ	I _N A	T _N Nm	Hz	GD ² kgm ²	kg
4	SUE001-112M-4-1500	1500	91.8%	0.96	7.28	25.5	75	0.00145	34
5.5	SUE001-132S-5.5-1500	1500	92.5%	0.96	9.93	35.0	75	0.00384	58
7.5	SUE001-132M-7.5-1500	1500	93.2%	0.96	13.4	47.8	75	0.00528	69
11	SUE001-160M-11-1500	1500	93.8%	0.96	19.6	70.0	100	0.0103	151
15	SUE001-160L-15-1500	1500	94.4%	0.96	26.5	95.5	100	0.0147	168
18.5	SUE001-180M-18.5-1500	1500	94.6%	0.96	32.7	118	100	0.0149	163
22	SUE001-180L-22-1500	1500	94.9%	0.96	38.7	140	100	0.0186	176
30	SUE001-200L-30-1500	1500	95.3%	0.96	52.6	191	100	0.0353	177
37	SUE001-225S-37-1500	1500	95.5%	0.96	64.7	236	100	0.0382	214
45	SUE001-225M-45-1500	1500	95.8%	0.96	78.5	287	100	0.0471	226
55	SUE001-250M-55-1500	1500	96.0%	0.96	95.7	350	100	0.0848	386
75	SUE001-280S-75-1500	1500	96.2%	0.96	130	478	100	0.105	386
90	SUE001-280M-90-1500	1500	96.5%	0.96	156	573	100	0.129	408
110	SUE001-315S-110-1500	1500	97.0%	0.96	189	700	100	0.461	700
132	SUE001-315ML-132-1500	1500	97.1%	0.96	227	840	100	0.567	738
160	SUE001-315ML-160-1500	1500	97.2%	0.96	275	1019	100	0.709	793
200	SUE001-315ML-200-1500	1500	97.4%	0.96	343	1273	100	0.851	840
250	SUE001-355ML-250-1500	1500	97.4%	0.96	429	1592	100	1.70	1265
280	SUE001-355ML-280-1500	1500	97.4%	0.96	480	1783	100	1.88	1315
315	SUE001-355ML-315-1500	1500	97.4%	0.96	540	2006	100	2.12	1382
355	SUE001-355ML-355-1500	1500	97.4%	0.96	609	2260	100	2.54	1505
400	SUE001-355ML-400-1500	1500	97.4%	0.96	686	2547	100	2.85	1596
450	SUE001-355ML-450-1500	1500	97.4%	0.96	772	2865	100	3.21	1702
500	SUE001-355ML-500-1500	1500	97.4%	0.96	858	3183	100	3.57	1809

IP55 - IC411 - 绝缘等级F, 温升等级B
 IE5效率等级数据根据 IEC 60034-30-2:2016
 标准机座: 同步转速 1000rpm 380V

IP55 - IC411 - Insulation class F, temperature class B
 IE5 according to IEC 60034-30-2:2016
 Standard Frame: Speed 1000rpm 380V

功率 Output	型号规格 Motor Type	额定转速 Speed	效率(100%) Efficiency 100%	功率因数 Power factor	额定电流 Current	额定转矩 Torque	频率 Frequency	转动惯量 Moment of inertia J = 1/4	重量 Weight
kW		r/min		cos ϕ	I _N A	T _N Nm	Hz	GD ² kgm ²	kg
4	SUE001-132M-4-1000	1000	92.7%	0.96	7.21	38.2	50	0.00528	69
5.5	SUE001-132M-5.5-1000	1000	93.4%	0.96	9.84	52.5	50	0.00673	76
7.5	SUE001-160M-7.5-1000	1000	94.0%	0.96	13.3	71.6	66.67	0.0118	162
11	SUE001-160L-11-1000	1000	94.5%	0.96	19.4	105	66.67	0.0162	177
15	SUE001-180L-15-1000	1000	94.9%	0.96	26.4	143	66.67	0.0186	178
18.5	SUE001-200L-18.5-1000	1000	95.3%	0.96	32.4	177	66.67	0.0324	172
22	SUE001-200L-22-1000	1000	95.6%	0.96	38.4	210	66.67	0.0382	182
30	SUE001-225M-30-1000	1000	95.8%	0.96	52.3	287	66.67	0.0471	226
37	SUE001-250M-37-1000	1000	96.0%	0.96	64.4	353	66.67	0.0848	386
45	SUE001-280S-45-1000	1000	96.2%	0.96	78.1	430	100	0.159	386
55	SUE001-280M-55-1000	1000	96.3%	0.96	95.4	525	100	0.194	408
75	SUE001-315S-75-1000	1000	96.4%	0.96	130	716	100	0.448	683
90	SUE001-315ML-90-1000	1000	96.5%	0.96	156	860	100	0.559	722
110	SUE001-315ML-110-1000	1000	96.6%	0.96	190	1051	100	0.671	762
132	SUE001-315ML-132-1000	1000	96.7%	0.96	228	1261	100	0.820	814
160	SUE001-355ML-160-1000	1000	96.8%	0.96	276	1528	100	1.57	1202
200	SUE001-355ML-200-1000	1000	97.0%	0.96	344	1910	100	1.95	1305
250	SUE001-355ML-250-1000	1000	97.0%	0.96	431	2388	100	2.45	1443

IP55 - IC411 - 绝缘等级F, 温升等级B
 IE5效率等级数据根据 IEC 60034-30-2:2016
 标准机座: 同步转速 750rpm 380V

IP55 - IC411 - Insulation class F, temperature class B
 IE5 according to IEC 60034-30-2:2016
 Standard Frame: Speed 750rpm 380V

功率 Output	型号规格 Motor Type	额定转速 Speed	效率(100%) Efficiency 100%	功率因数 Power factor	额定电流 Current	额定转矩 Torque	频率 Frequency	转动惯量 Moment of inertia J = 1/4	重量 Weight
kW		r/min		cos ϕ	I _N A	T _N Nm	Hz	GD ² kgm ²	kg
4	SUE001-160M-4-750	750	90.2%	0.96	7.41	50.9	50	0.00884	152
5.5	SUE001-160M-5.5-750	750	90.9%	0.96	10.1	70.0	50	0.0118	162
7.5	SUE001-160L-7.5-750	750	91.5%	0.96	13.7	95.5	50	0.0162	182
11	SUE001-180L-11-750	750	92.7%	0.96	19.8	140	50	0.0205	176
15	SUE001-200L-15-750	750	93.3%	0.96	26.9	191	50	0.0353	177
18.5	SUE001-225S-18.5-750	750	94.0%	0.96	32.9	236	50	0.0412	218
22	SUE001-225M-22-750	750	94.5%	0.96	38.9	280	50	0.0529	234
30	SUE001-250M-30-750	750	94.7%	0.96	52.9	382	50	0.0918	408
37	SUE001-280S-37-750	750	95.0%	0.96	65.1	471	75	0.177	395
45	SUE001-280M-45-750	750	95.2%	0.96	79.0	573	75	0.212	416
55	SUE001-315S-55-750	750	95.4%	0.96	96.3	700	75	0.448	683
75	SUE001-315ML-75-750	750	95.6%	0.96	131	955	75	0.597	738
90	SUE001-315ML-90-750	750	95.7%	0.96	157	1146	75	0.746	793
110	SUE001-315ML-110-750	750	95.6%	0.96	192	1401	75	0.895	840
132	SUE001-355ML-132-750	750	95.9%	0.96	230	1681	75	1.70	1237
160	SUE001-355ML-160-750	750	96.1%	0.96	278	2037	75	2.08	1339
200	SUE001-355ML-200-750	750	96.3%	0.96	347	2547	75	2.58	1477

IP55 - IC411 - 绝缘等级F, 温升等级B
 IE5效率等级数据根据 IEC 60034-30-2:2016
 缩小机座: 同步转速 3000rpm 380V

IP55 - IC411 - Insulation class F, temperature class B
 IE5 according to IEC 60034-30-2:2016
 Small Frame: Speed 3000rpm 380V

功率 Output	型号规格 Motor Type	额定转速 Speed	效率(100%) Efficiency 100%	功率因数 Power factor	额定电流 Current	额定转矩 Torque	频率 Frequency	转动惯量 Moment of inertia J = 1/4	重量 Weight
kW		r/min		cos ϕ	I _N A	T _N Nm	Hz	GD ² kgm ²	kg
5.5	SUE001-112M-5.5-3000	3000	94.0%	0.96	9.77	17.5	150	0.00114	33
7.5	SUE001-112M-7.5-3000	3000	94.5%	0.96	13.3	23.9	150	0.00156	34
22	SUE001-160M-22-3000	3000	95.9%	0.96	38.3	70.0	200	0.01032	151
30	SUE001-160M-30-3000	3000	96.1%	0.96	52.2	95.5	200	0.0162	177
37	SUE001-160M-37-3000	3000	96.3%	0.96	64.2	118	200	0.0221	190
45	SUE001-180M-45-3000	3000	96.4%	0.96	78.0	143	200	0.0205	184
55	SUE001-180M-55-3000	3000	96.5%	0.96	95.2	175	200	0.0242	192
75	SUE001-200L-75-3000	3000	96.6%	0.96	130	239	200	0.0500	200
90	SUE001-200L-90-3000	3000	96.7%	0.96	155	287	200	0.0588	213
110	SUE001-250M-110-3000	3000	96.8%	0.96	190	350	200	0.106	413
132	SUE001-250M-132-3000	3000	96.9%	0.96	228	420	200	0.127	424
160	SUE001-250M-160-3000	3000	97.0%	0.96	276	509	200	0.155	474
200	SUE001-280S-200-3000	3000	97.2%	0.96	344	637	200	0.257	500
250	SUE001-280M-250-3000	3000	97.2%	0.96	430	796	200	0.351	592
280	SUE001-280M-280-3000	3000	97.2%	0.96	481	891	200	0.397	629
315	SUE001-280ML-315-3000	3000	97.2%	0.96	541	1003	200	0.432	672
355	SUE001-280ML-355-3000	3000	97.2%	0.96	610	1130	200	0.479	709
400	SUE001-280ML-400-3000	3000	97.2%	0.96	687	1273	200	0.538	756
450	SUE001-315ML-450-3000	3000	97.2%	0.96	773	1433	200	1.170	973
500	SUE001-315ML-500-3000	3000	97.2%	0.96	859	1592	200	1.276	1010

IP55 - IC411 - 绝缘等级F, 温升等级B

IE5效率等级数据根据 IEC 60034-30-2:2016

缩小机座: 同步转速 1500rpm 380V

IP55 - IC411 - Insulation class F, temperature class B

IE5 according to IEC 60034-30-2:2016

Small Frame: Speed 1500rpm 380V

功率 Output	型号规格 Motor Type	额定转速 Speed	效率(100%) Efficiency 100%	功率因数 Power factor	额定电流 Current	额定转矩 Torque	频率 Frequency	转动惯量 Moment of inertia J = 1/4	重量 Weight
kW		r/min		cos ϕ	I _N A	T _N Nm	Hz	GD ² kgm ²	kg
5.5	SUE001-112M-5.5-1500	1500	92.5%	0.96	9.93	35.0	75	0.00208	36
18.5	SUE001-160M-18.5-1500	1500	94.6%	0.96	32.7	118	100	0.0177	181
22	SUE001-160M-22-1500	1500	94.9%	0.96	38.7	140	100	0.0221	190
30	SUE001-160L-30-1500	1500	95.3%	0.96	52.6	191	100	0.0295	211
37	SUE001-180M-37-1500	1500	95.5%	0.96	64.7	236	100	0.0298	216
45	SUE001-180M-45-1500	1500	95.8%	0.96	78.5	287	100	0.0373	240
55	SUE001-200L-55-1500	1500	96.0%	0.96	95.7	350	100	0.0588	213
75	SUE001-250M-75-1500	1500	96.2%	0.96	130	478	100	0.113	358
90	SUE001-250M-90-1500	1500	96.5%	0.96	156	573	100	0.134	372
110	SUE001-250M-110-1500	1500	97.0%	0.96	189	700	100	0.170	471
132	SUE001-250M-132-1500	1500	97.1%	0.96	227	840	100	0.205	510
160	SUE001-280S-160-1500	1500	97.2%	0.96	275	1019	100	0.281	542
200	SUE001-280M-200-1500	1500	97.4%	0.96	343	1273	100	0.374	607
250	SUE001-280ML-250-1500	1500	97.4%	0.96	429	1592	100	0.468	697
280	SUE001-315ML-280-1500	1500	97.4%	0.96	480	1783	100	1.42	995
315	SUE001-315ML-315-1500	1500	97.4%	0.96	540	2006	100	1.42	1048
355	SUE001-315ML-355-1500	1500	97.4%	0.96	609	2260	100	1.60	1100

IP55 - IC411 - 绝缘等级F, 温升等级B
 IE5效率等级数据根据 IEC 60034-30-2:2016
 缩小机座: 同步转速 1000rpm 380V

IP55 - IC411 - Insulation class F, temperature class B
 IE5 according to IEC 60034-30-2:2016
 Small Frame: Speed 1000rpm 380V

功率 Output	型号规格 Motor Type	额定转速 Speed	效率(100%) Efficiency 100%	功率因数 Power factor	额定电流 Current	额定转矩 Torque	频率 Frequency	转动惯量 Moment of inertia J = 1/4	重量 Weight
kW		r/min		cos ϕ	I _N A	T _N Nm	Hz	GD ² kgm ²	kg
18.5	SUE001-160M-18.5-1000	1000	95.3%	0.96	32.4	177	66.67	0.0265	200
22	SUE001-180M-22-1000	1000	95.6%	0.96	38.4	210	66.67	0.0280	211
30	SUE001-180M-30-1000	1000	95.8%	0.96	52.3	287	66.67	0.0373	240
37	SUE001-200L-37-1000	1000	96.0%	0.96	64.4	353	66.67	0.0588	213
45	SUE001-200L-45-1000	1000	96.2%	0.96	78.1	430	66.67	0.106	413
55	SUE001-250M-55-1000	1000	96.3%	0.96	95.4	525	66.67	0.127	424
75	SUE001-250M-75-1000	1000	96.4%	0.96	130	716	66.67	0.184	490
90	SUE001-280S-90-1000	1000	96.5%	0.96	156	860	100	0.318	469
110	SUE001-280S-110-1000	1000	96.6%	0.96	190	1051	100	0.388	523
132	SUE001-280M-132-1000	1000	96.7%	0.96	228	1261	100	0.459	560
160	SUE001-280M-160-1000	1000	96.8%	0.96	276	1528	100	0.547	623
200	SUE001-280ML-200-1000	1000	97.0%	0.96	344	1910	100	0.689	697
250	SUE001-315ML-250-1000	1000	97.0%	0.96	431	2388	100	1.57	1076
280	SUE001-315ML-280-1000	1000	97.0%	0.96	482	2674	100	1.75	1141
315	SUE001-315ML-315-1000	1000	97.0%	0.96	543	3008	100	3.15	1632
355	SUE001-355ML-355-1000	1000	97.0%	0.96	611	3390	100	3.52	1735
400	SUE001-355ML-400-1000	1000	97.0%	0.96	689	3820	100	3.96	1877

IP55 - IC411 - 绝缘等级F, 温升等级B

IE5效率等级数据根据 IEC 60034-30-2:2016

缩小机座: 同步转速 750rpm 380V

IP55 - IC411 - Insulation class F, temperature class B

IE5 according to IEC 60034-30-2:2016

Small Frame: Speed 750rpm 380V

功率 Output	型号规格 Motor Type	额定转速 Speed	效率(100%) Efficiency 100%	功率因数 Power factor	额定电流 Current	额定转矩 Torque	频率 Frequency	转动惯量 Moment of inertia J = 1/4	重量 Weight
kW		r/min		cos ϕ	I _N A	T _N Nm	Hz	GD ² kgm ²	kg
11	SUE001-160M-11-750	750	92.7%	0.96	19.8	140	50	0.0236	194
15	SUE001-180M-15-750	750	93.3%	0.96	26.9	191	50	0.0242	192
18.5	SUE001-180M-18.5-750	750	94.0%	0.96	32.9	236	50	0.0298	216
22	SUE001-180M-22-750	750	94.5%	0.96	38.9	280	50	0.0373	240
30	SUE001-180L-30-750	750	94.7%	0.96	52.9	382	50	0.0647	240
37	SUE001-200L-37-750	750	95.0%	0.96	65.1	471	50	0.120	408
45	SUE001-250M-45-750	750	95.2%	0.96	79.0	573	50	0.141	450
55	SUE001-250M-55-750	750	95.4%	0.96	96.3	700	50	0.170	481
75	SUE001-280S-75-750	750	95.6%	0.96	131	955	75	0.353	487
90	SUE001-280M-90-750	750	95.6%	0.96	157	1146	75	0.424	542
110	SUE001-280M-110-750	750	95.7%	0.96	192	1401	75	0.512	588
132	SUE001-280ML-132-750	750	95.9%	0.96	230	1681	75	0.618	660
160	SUE001-280ML-160-750	750	96.1%	0.96	278	2037	75	0.741	724
200	SUE001-315ML-200-750	750	96.3%	0.96	347	2547	75	1.64	1102
250	SUE001-355ML-250-750	750	96.3%	0.96	434	3183	75	3.27	1666
280	SUE001-355ML-280-750	750	96.3%	0.96	486	3565	75	3.65	1589

变量代码 / Variant codes

代码 Code	内容 Description	112	132	160	180	200	225	250	280	315	355	备注
安装方式 Mounting arrangements												
MA01	B3 安装形式 Foot mounted	S	S	S	S	S	S	S	S	S	S	标配
MA02	B5 安装形式 BigFlange mounted	P	P	P	P	P	P	P	P	P	P	
MA03	V1 安装形式 Flange mounted	P	P	P	P	P	P	P	P	P	P	
MA04	B35 安装形式 Foot/flange mounted	P	P	P	P	P	P	P	P	P	P	
MA05	B14 安装形式 SmallFlange mounted	P	P	P	NA	NA	NA	NA	NA	NA	NA	
MA06	B34 安装形式 IM B34 (2101)	P	P	P	NA	NA	NA	NA	NA	NA	NA	
MA07	除上之外其他标准安装形式 Others	R	R	R	R	R	R	R	R	R	R	
接线盒 Terminal box												
TB01	顶出线接线盒 TopTerminalBox	S	S	S	S	S	S	S	S	S	S	标配
TB02	接线盒出线孔朝 D 端 Cable entry from D-end.	P	P	P	P	P	P	P	P	P	P	
TB03	接线盒出线孔朝 N 端 Cable entry from N-end.	P	P	P	P	P	P	P	P	P	P	
TB04	接线盒出线孔朝左侧 (从 D 端看) Cable entry LHS (seen from D-end)	P	P	P	P	P	P	P	P	P	P	
TB05	特殊要求接线盒 SpecialTerminalBox	R	R	R	R	R	R	R	R	R	R	
TB06	右侧接线盒 (从 D 端看) Terminal box RHS (seen from D-end)	P	P	P	P	P	P	P	P	P	P	
TB07	左侧接线盒 (从 D 端看) Terminal box LHS (seen from D-end)	P	P	P	P	P	P	P	P	P	P	
TB08	延长电缆线, 压板式, 散线引出, 标准长度 Extended cable connection, no terminal box (StandardLength)	P	P	P	P	P	P	P	P	P	P	
TB09	延长电缆线, 压板式, 散线引出, 特殊长度 Extended cable connection, no terminal box. (SpecialLength)	R	R	R	R	R	R	R	R	R	R	
TB10	延长电缆线, 压板式, 特殊电缆 Extended Specialcable connection, no terminal box	R	R	R	R	R	R	R	R	R	R	
TB11	另附一套标准接线盒 AnotherStandardTerminalBox	P	P	P	P	P	P	P	P	P	P	
TB12	用于检测装置的独立接线盒 Separate terminal box for auxiliaries, standard material	NA	NA	P	P	P	P	P	P	P	P	
TB13	EMC 电缆密封管 EMC cable entry	R	R	R	R	R	R	R	R	R	R	
TB14	2 个标准金属电缆密封管 Two standard metal cable entry	P	P	P	P	P	P	P	P	P	P	

S = 标准配置
 R = 需技术确认
 NA = 不适用
 P = 按定型方案直接排产

S = Included as standard
 R = On request
 NA = Not applicable
 P = Applicable

变量代码 / Variant codes

代码 Code	内容 Description	112	132	160	180	200	225	250	280	315	355	备注
TB15	2个标准塑料电缆密封管 Two standard plastic cable entry	S	S	S	S	S	S	S	S	S	S	标配
TB16	2个标准不锈钢电缆密封管 Two standard stainless steel cable entry	R	R	R	R	R	R	R	R	R	R	
TB17	接线盒在 N 端 TerminalBoxatN-end	P	P	P	P	P	P	P	P	P	P	
TB18	预留非标出线孔 Reserve non-standard cable entry	R	R	R	R	R	R	R	R	R	R	
TB19	一个标准金属电缆密封管 One standard metal cable entry	P	P	P	P	P	P	P	P	P	P	
轴承及润滑												
Bearings and Lubrication												
BL01	D 端圆柱滚子轴承 Roller bearing at D-end	NA	NA	P	P	P	P	P	P	P	P	
BL02	密封式轴承 Bearings greased for life	S	S	S	P	P	P	R	R	R	R	
BL03	耐高温润滑脂 Heat-resistant grease	R	R	R	R	R	R	R	R	R	R	
BL04	耐低温润滑脂 Cold-resistant grease	P	P	P	P	P	P	P	P	P	P	
BL05	轴承装运锁 Transport lock for bearings	NA	NA	P	P	P	P	P	P	P	P	
BL06	轴承安装 PT100 (3 线) 2 只 Pt100 3-wire in bearings	NA	NA	P	P	P	P	P	P	P	P	
BL07	轴承安装 PT100 (2 线) 2 只 Pt100 2-wire in bearings	NA	NA	P	P	P	P	P	P	P	P	
BL08	SKF 轴承 SKFBearing	P	P	P	P	P	P	P	P	P	P	
BL09	D 端角接触球轴承, 轴向力远离轴承 Angular contact bearing at D-end, shaft force away from bearing	NA	NA	R	R	R	R	R	R	R	R	
BL10	D 端角接触球轴承, 轴向力指向轴承 Angular contact bearing at D-end, shaft force towards bearing	NA	NA	R	R	R	R	R	R	R	R	
BL11	63 系列轴承 63 seriesbearing	S	S	S	S	S	S	S	S	S	S	标配
BL12	预留 SPM 振动测量探头 SPM compatible nipples for vibration measurement	NA	NA	P	P	P	P	P	P	P	P	
BL13	可通过注油嘴润滑的轴承 Bearings regreasable via grease nipples	NA	NA	P	S	S	S	S	S	S	S	标配
绝缘												
Insulation system												
IS01	F 级绝缘 Winding insulation class F	S	S	S	S	S	S	S	S	S	S	标配
IS02	H 级绝缘 Winding insulation class H	R	R	R	R	R	R	R	R	R	R	

S = 标准配置
 R = 需技术确认
 NA = 不适用
 P = 按定型方案直接排产

S = Included as standard
 R = On request
 NA = Not applicable
 P = Applicable

变量代码 / Variant codes

代码 Code	内容 Description	112	132	160	180	200	225	250	280	315	355	备注
定子绕组 Stator winding temperature sensors												
SW01	定子绕组安装温度开关(常闭型, 3个串联, 150°C) Bimetal detectors, break type (NCC), (3 in series), 150°C, in stator winding	R	R	R	R	R	R	R	R	R	R	R
SW02	定子绕组安装温度开关(常闭型, 3个串联, 170°C) Bimetal detectors, break type (NCC), (3 in series), 170°C, in stator winding	R	R	R	R	R	R	R	R	R	R	R
SW03	定子绕组安装 PT100 (2线), 每相1个 Pt100 2-wire in stator winding, 1 per phase	P	P	P	P	P	P	P	P	P	P	P
SW04	定子绕组安装 PT100 (2线), 每相2个 Pt100 2-wire in stator winding, 2 per phase	P	P	P	P	P	P	P	P	P	P	P
SW05	定子绕组安装 PT100 (3线), 每相1个 Pt100 3-wire in stator winding, 1 per phase	P	P	P	P	P	P	P	P	P	P	P
SW06	定子绕组安装 PT100 (3线), 每相2个 Pt100 3-wire in stator winding, 2 per phase	P	P	P	P	P	P	P	P	P	P	P
SW07	定子绕组安装 PTC 热敏电阻 (3个串联, 150°C) PTC - thermistors (3 in series), 150°C, in stator winding	R	R	R	R	R	R	R	R	R	R	R
SW08	定子绕组安装 PTC 热敏电阻 (3个串联, 170°C) PTC - thermistors (3 in series), 170°C, in stator winding	R	R	R	R	R	R	R	R	R	R	R
SW11	定子绕组安装 2组 PTC 热敏电阻 (3个串联, 150°C) PTC - thermistors (2x3 in series), 150°C, in stator winding	R	R	R	R	R	R	R	R	R	R	R
SW12	定子绕组安装 2组 PTC 热敏电阻 (3个串联, 130°C 和 3个串联, 150°C) PTC - thermistors (3 in series, 130°C & 3 in series, 150°C), in stator winding	R	R	R	R	R	R	R	R	R	R	R
SW13	定子绕组安装 PTC 热敏电阻 (3个串联, 130°C) PTC - thermistors (3 in series), 130°C, in stator winding	S	S	S	S	S	S	S	S	S	S	S
SW14	定子绕组安装温度开关 (常闭型, 3个串联, 130°C) Bimetal detectors, break type (NCC), (3 in series), 130°C, in stator winding	R	R	R	R	R	R	R	R	R	R	R

S = 标准配置

S = Included as standard

R = 需技术确认

R = On request

NA = 不适用

NA = Not applicable

P = 按定型方案直接排产

P = Applicable

变量代码 / Variant codes

代码 Code	内容 Description	112	132	160	180	200	225	250	280	315	355	备注
转轴 Shaft & rotor												
SR01	标准双轴伸 Two shaft extensions according to catalog drawings	P	P	P	P	P	P	P	P	P	P	
SR02	闭口键槽轴伸 Shaft extension with closed keyway	S	S	S	S	S	S	S	S	S	S	标配
SR03	轴伸带螺纹孔 Shaft extension with threaded openings	S	S	S	S	S	S	S	S	S	S	
SR04	D 端特殊轴伸 (标准材料) Special shaft extension at D-End, standard shaft material	R	R	R	R	R	R	R	R	R	R	
SR05	N 端特殊轴伸 (标准材料) Special shaft extension at N-end, standard shaft material	R	R	R	R	R	R	R	R	R	R	
SR06	不锈钢轴 (标准或非标设计) Shaft material stainless steel	R	R	R	R	R	R	R	R	R	R	
SR07	开口键槽轴伸 Shaft extension with open keyway	P	P	P	P	P	P	P	P	P	P	B 型键
防护 Protection												
IP01	IP55 防护等级 Degree of protection IP55	S	S	S	S	S	S	S	S	S	S	标配
IP02	IP56 防护等级 Degree of protection IP56	P	P	P	P	P	P	P	P	P	P	
IP03	IP65 防护等级 Degree of protection IP65	P	P	P	P	P	P	P	P	P	P	
IP04	带冷凝水排水孔 Condensed water drain holes	P	P	P	P	P	P	P	P	P	P	高湿度环境推荐
IP05	外接地 External earthing bolt	P	P	P	P	P	P	P	P	S	S	
IP06	不锈钢螺栓 (304#) Stainless steel	P	P	P	P	P	P	P	P	P	P	
IP07	D 端径向密封 Radial seal at D-end.	P	P	P	P	P	P	P	P	P	P	
IP08	湿热带型 TH TH design	R	R	R	R	R	R	R	R	R	R	
IP09	户外防中等腐蚀型 WF1 Outdoor medium anti-corrosion WF1	R	R	R	R	R	R	R	R	R	R	
IP10	户外防强腐蚀型 WF2 Outdoor medium anti-corrosion WF2	R	R	R	R	R	R	R	R	R	R	
IP11	IP66 防护等级 Degree of protection IP66	R	R	R	R	R	R	R	R	R	R	
IP12	定转子防潮处理 Moisture-proof treatment of stator and rotor	R	R	R	R	R	R	R	R	R	R	高湿度环境推荐

S = 标准配置
R = 需技术确认
NA = 不适用
P = 按定型方案直接排产

S = Included as standard
R = On request
NA = Not applicable
P = Applicable

变量代码 / Variant codes

代码 Code	内容 Description	112	132	160	180	200	225	250	280	315	355	备注
冷却系统 Cooling system												
CS01	塑料风扇 Plastic fan	S	S	S	S	S	S	S	S	S	S	标配
CS02	铝合金风扇 Light alloy metal fan	P	P	P	P	P	P	P	P	P	P	
CS03	无风扇风罩 Cooling method IC418 (without fan)	P	P	P	P	P	P	P	P	P	P	
CS04	独立冷却风机 Separate motor cooling	P	P	P	P	P	P	P	P	P	P	
铭牌 Rating & instruction plates												
NP01	重敲铭牌异电压、异频率、异功率、异工作制 Restamping voltage, frequency and output, continuous duty	R	R	R	R	R	R	R	R	R	R	
NP02	加装额外的不锈钢指示牌 (铭牌) Mounting of additional identification plate, stainless	P	P	P	P	P	P	P	P	P	P	
NP03	附加指示牌 (铭牌) 单独交付 Additional signs (nameplates) to be delivered separately	P	P	P	P	P	P	P	P	P	P	
加热带 Heating elements												
HE01	加热带 110-120V Heating element, 100-120 V	P	P	P	P	P	P	P	P	P	P	
HE02	加热带 220-240V Heating element, 200 - 240 V	P	P	P	P	P	P	P	P	P	P	
油漆 Painting												
SP01	仅喷底漆 Primer paint only	P	P	P	P	P	P	P	P	P	P	
SP02	喷特殊颜色面漆, 标准等级 Special paint color, standard grade	P	P	P	P	P	P	P	P	P	P	
SP03	喷涂厚度报告 Painting thickness report	P	P	P	P	P	P	P	P	P	P	
变频 Variable speed drives												
SD04	变频铭牌数据根据要求定制 Frequency converter rating plate. Rating data according to quotation.	R	R	R	R	R	R	R	R	R	R	
SD06	安装编码器 Pulse tachometer	R	R	R	R	R	R	R	R	R	R	
SD07	N 端绝缘轴承 Insulated bearing at N-end.	NA	NA	NA	NA	R	R	P	P	P	P	
SD08	变频铭牌数据根据要求定制 Frequency converter rating plate. Rating data according to quotation	R	R	R	R	R	R	R	R	R	R	

S = 标准配置
R = 需技术确认
NA = 不适用
P = 按定型方案直接排产

S = Included as standard
R = On request
NA = Not applicable
P = Applicable

变量代码 / Variant codes

代码 Code	内容 Description	112	132	160	180	200	225	250	280	315	355	备注
测试 Test												
T01	目录电机的型式试验报告 (380V/50HZ) Type test report from a catalogue motor (380V 50Hz)	R	R	R	R	R	R	R	R	R	R	
T02	指定批次内的某一电机的型式试验及报告 Type test with report for one motor from specific delivery batch	P	P	P	P	P	P	P	P	P	P	
T03	出厂试验报告 Routine test report	P	P	P	P	P	P	P	P	P	P	
T04	振动等级测试 Vibration level test	P	P	P	P	P	P	P	P	P	P	
T05	噪声水平测试 Noise level test	P	P	P	P	P	P	P	P	P	P	
包装 Packing												
P01	出口木箱包装 Wooden sea freight packing	P	P	P	P	P	P	P	P	P	P	
平衡 Balancing												
B01	全键平衡 Full-key balancing	P	P	P	P	P	P	P	P	P	P	
B02	半键平衡 Half-key balancing	S	S	S	S	S	S	S	S	S	S	
B03	无键平衡 Balanced without key	P	P	P	P	P	P	P	P	P	P	
B04	B级振动等级 Vibration acc. to Grade B	P	P	P	P	P	P	P	P	P	P	
质保 Warranty												
W01	延长质保 Extension on standard warranty	R	R	R	R	R	R	R	R	R	R	
其他 Others												
U00	其他要求 Others	R	R	R	R	R	R	R	R	R	R	

S = 标准配置 S = Included as standard
 R = 需技术确认 R = On request
 NA = 不适用 NA = Not applicable
 P = 按定型方案直接排产 P = Applicable

外形图及外形尺寸 / Dimension drawings

机座号 112~132 / FrameSize 112~132

底脚安装电机 IMB3 Foot-mounted motor IMB3

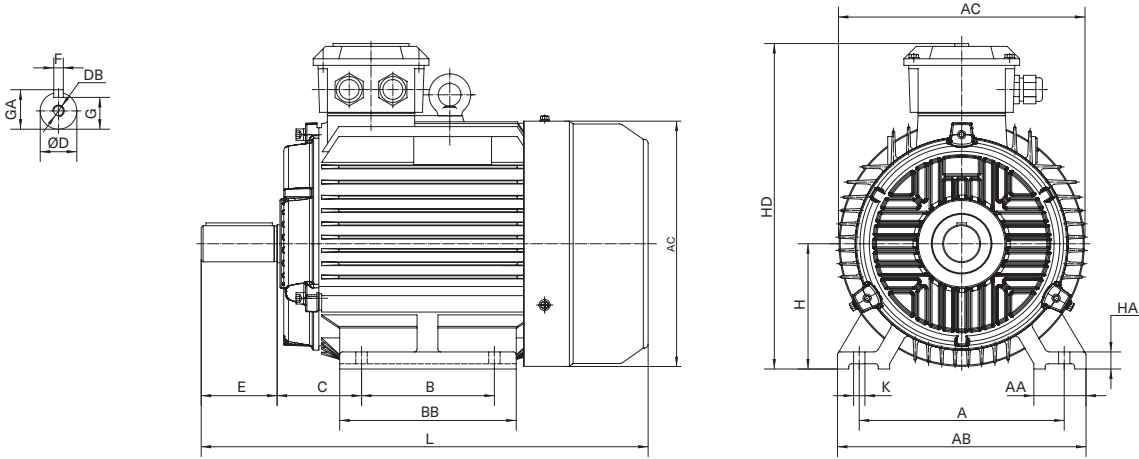

大凸缘安装电机 IMB5、IMV1、IMV3 BigFlange-mounted motor IMB5、IMV1、IMV3

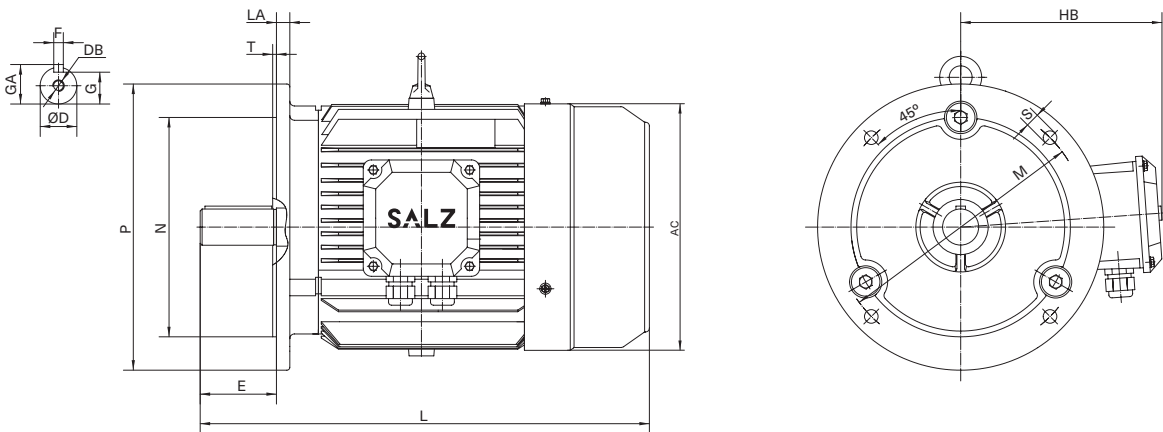

底脚和大凸缘安装电机 IMB35 Foot- and big flange-mounted motor IMB35

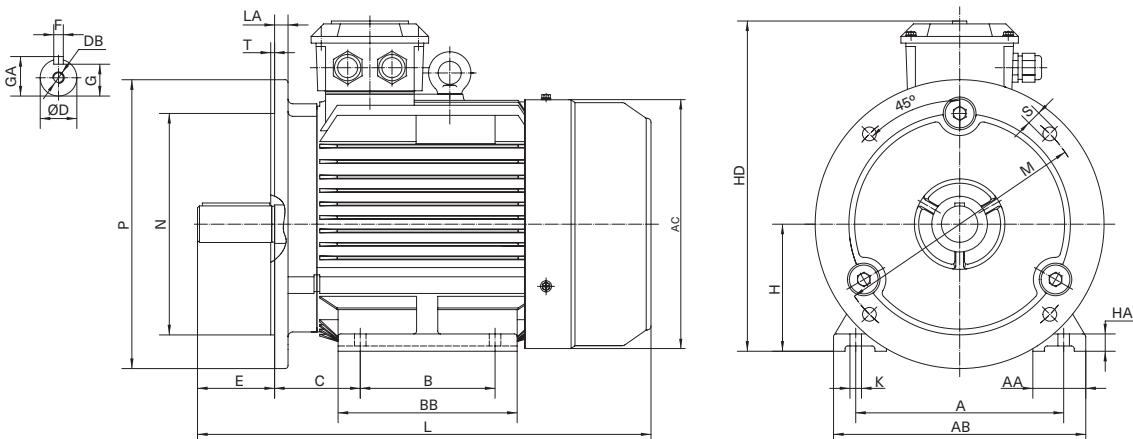

外形图及外形尺寸 / Dimension drawings

机座号 112~132 / FrameSize 112~132

小凸缘安装电机 IMB14

Small flange-mounted motor IMB14

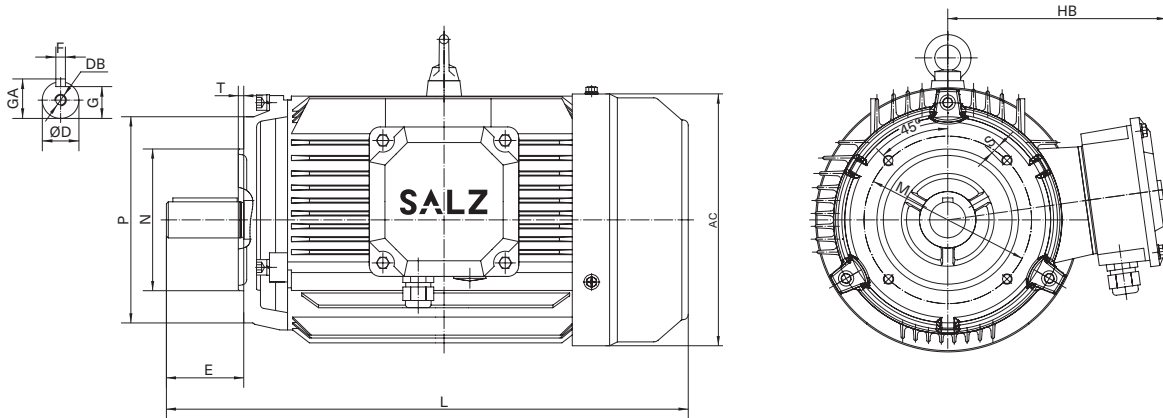

底脚和小凸缘安装电机 IMB34

Foot- and small flange-mounted motor IMB34

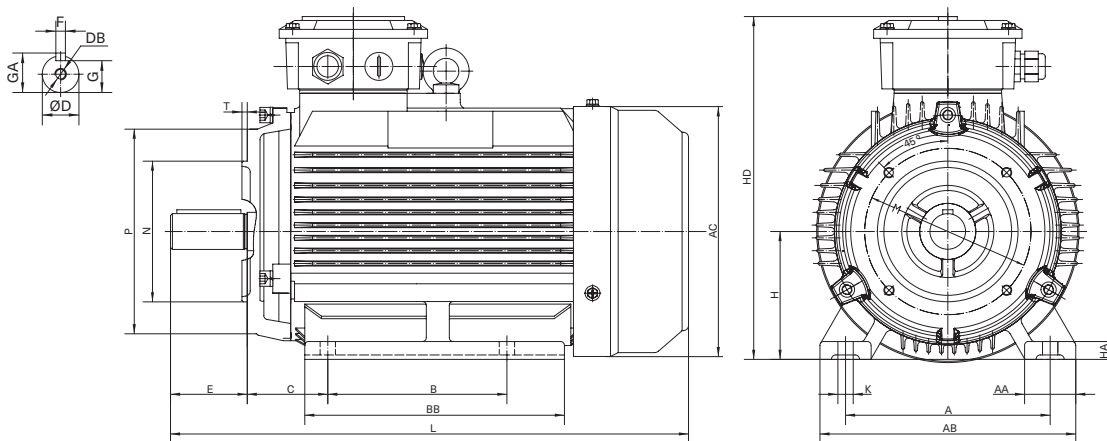

外形图及外形尺寸 / Dimension drawings

机座号 112~132 / FrameSize 112~132

IMB3 ; IMB35 ; IMB34

机座 Frame Size	A	AA	AB	AC	B	BB	C	D	DB	E	F	G	GA	H	K	HA	HD	L
112	190	45	226	220	140	180	70	28	M10	60	8	24	31	112	12	15	315	400
132S	216	55	262	260	140	186	89	38	M12	80	10	33	41	132	12	18	355	470
132M	216	55	262	260	178	224	89	38	M12	80	10	33	41	132	12	18	355	510

IMB5、IMV1、IMV3 ; IMB35

机座 Frame Size	HB	LA	M	N	P	S	T
112	203	14	215	180	250	14.5	4
132	223	14	265	230	300	14.5	4

注：电机立式向下安装时，该电机总长度 L 不包括增加的防雨帽长度。

IMB14 ; IMB34

机座 Frame Size	HB	M	N	P	S	T
112	203	130	110	160	M8	4
132	223	165	130	200	M10	4

Note: When the motor is installed vertically downwards, the total length L of the motor does not include the added length of the protective roof.

外形图及外形尺寸 / Dimension drawings

机座号 160~225 / Frame Size 160~225

底脚安装电机IMB3 Foot-mounted motor IMB3

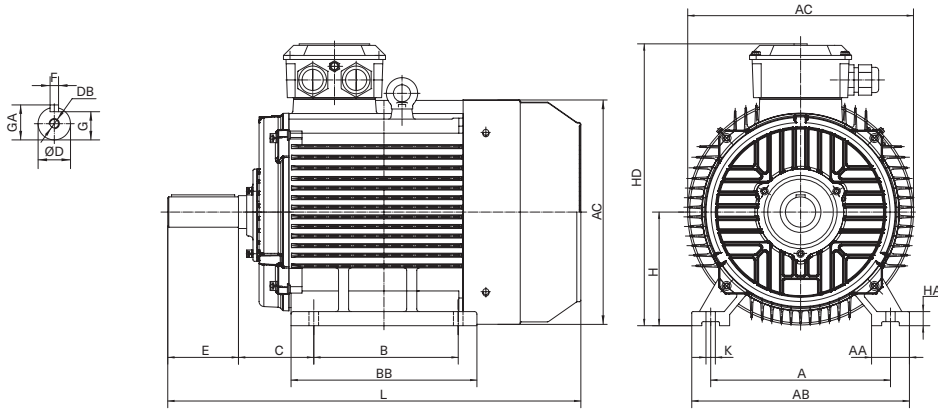

大凸缘安装电机 IMB5、IMV1、IMV3 Big Flange-mounted motor IMB5、IMV1、IMV3

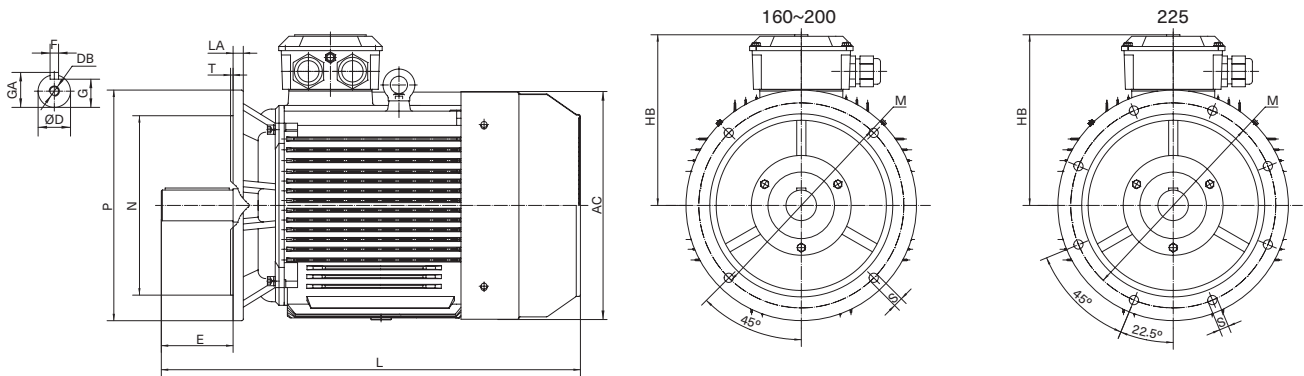

底脚和大凸缘安装电机 IMB35 Foot- and big flange-mounted motor IMB35

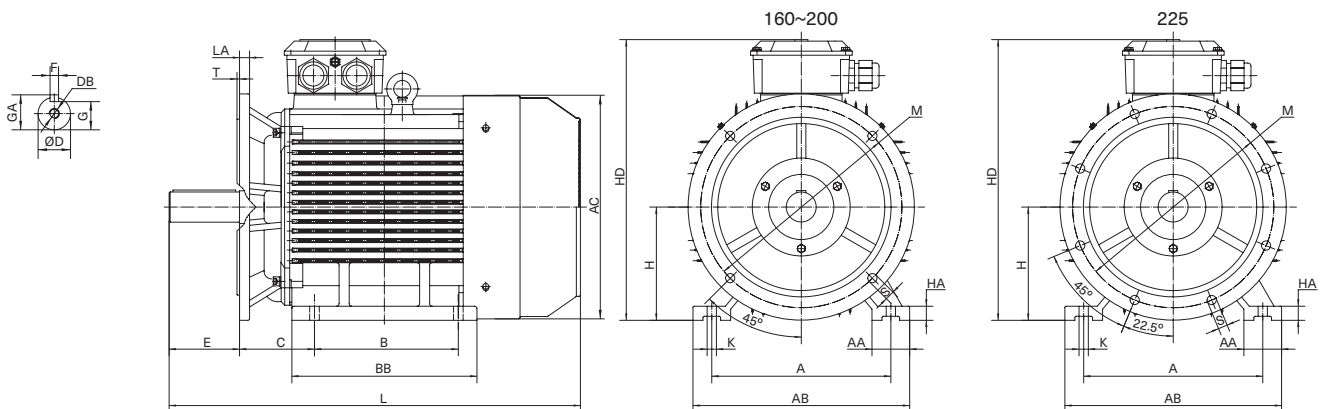

外形图及外形尺寸 / Dimension drawings

机座号 160~225 / Frame Size 160~225

IMB3、IMB6、IMB7、IMB8、IMV5、IMV6 ; IMB35、IMV15、IMV36

机座 Frame Size	转速 Speed r/min	A	AA	AB	AC	B	BB	C	D	DB	E	F	G	GA	H	K	HA	HD	L
160M	750~3000	254	65	314	315	210	260	108	42	M16	110	12	37	45	160	14.5	20	435	625
160L	750~3000	254	65	314	315	254	304	108	42	M16	110	12	37	45	160	14.5	20	435	670
180M	750~3000	279	70	349	355	241	311	121	48	M16	110	14	42.5	51.5	180	14.5	22	470	700
180L	750~3000	279	70	349	355	279	349	121	48	M16	110	14	42.5	51.5	180	14.5	22	470	735
200L	750~3000	318	70	388	400	305	369	133	55	M20	110	16	49	59	200	18.5	25	525	775
225S	750~1500	356	91	430	400	286	390	149	60	M20	140	18	53	64	225	18.5	50	550	805
225M	3000	356	91	430	400	311	390	149	55	M20	110	16	49	59	225	18.5	50	550	775
225M	750~1500	356	91	430	400	311	390	149	60	M20	140	18	53	64	225	18.5	50	550	805

IMB5、IMV1、IMV3 ; IMB35、IMV15、IMV36

机座 Frame Size	转速 Speed r/min	HB	LA	M	N	P	S	T
160M	750~3000	275	15	300	250	350	18.5	5
160L	750~3000	275	15	300	250	350	18.5	5
180M	750~3000	290	15	300	250	350	18.5	5
180L	750~3000	290	15	300	250	350	18.5	5
200L	750~3000	325	17	350	300	400	18.5	5
225S	750~1500	325	20	400	350	450	18.5	5
225M	3000	325	20	400	350	450	18.5	5
225M	750~1500	325	20	400	350	450	18.5	5

注：电机立式向下安装时，该电机总长度 L 不包括增加的防雨帽长度。

Note: When the motor is installed vertically downwards, the total length L of the motor does not include the added length of the protective roof.

外形图及外形尺寸 / Dimension drawings

机座号 250~280 / Frame Size 250~280

底脚安装电机 IMB3、IMB6、IMB7、IMB8、IMV5、IMV6
Foot-mounted motor IMB3、IMB6、IMB7、IMB8、IMV5、IMV6

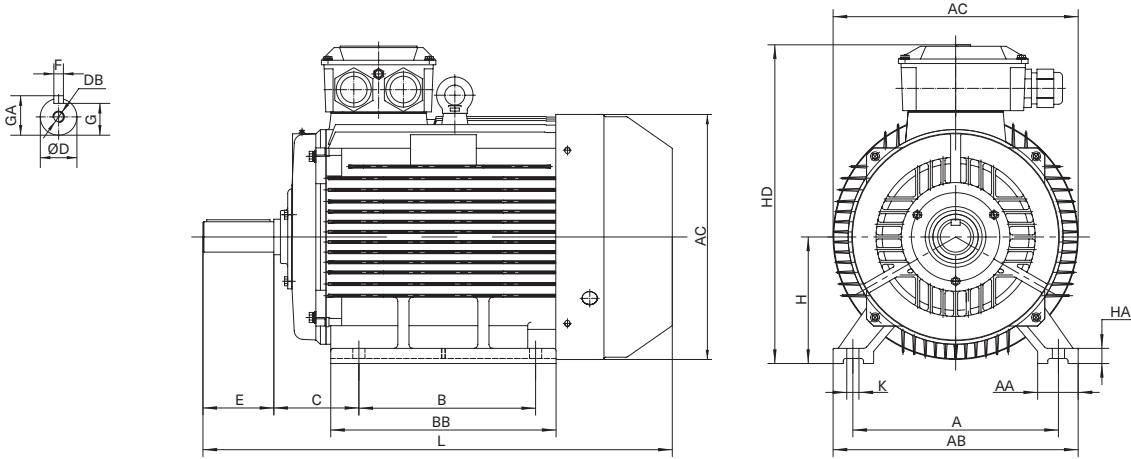

凸缘安装电机 IMB5、IMV1、IMV3
Big Flange-mounted motor IMB5、IMV1、IMV3

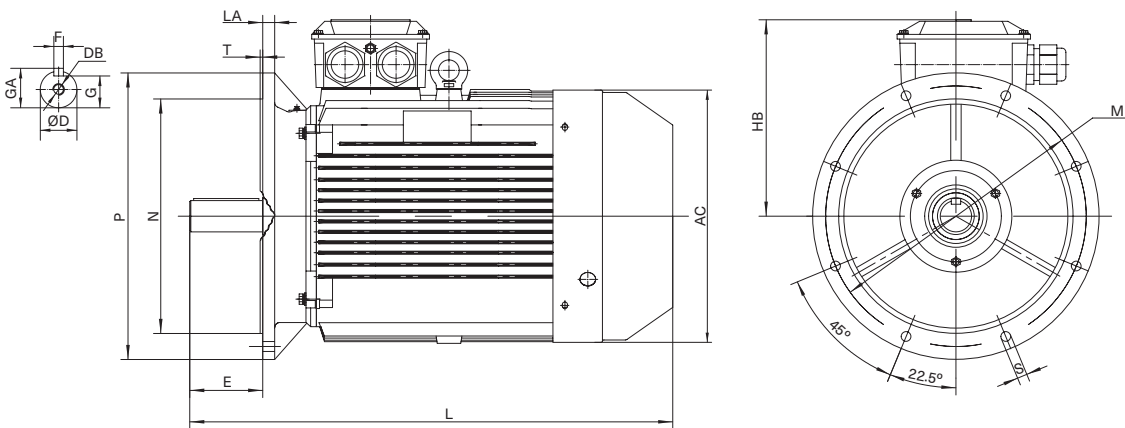

底脚和凸缘安装电机 IMB35、IMV15、IMV36
Foot- and big flange-mounted motor IMB35、IMV15、IMV36

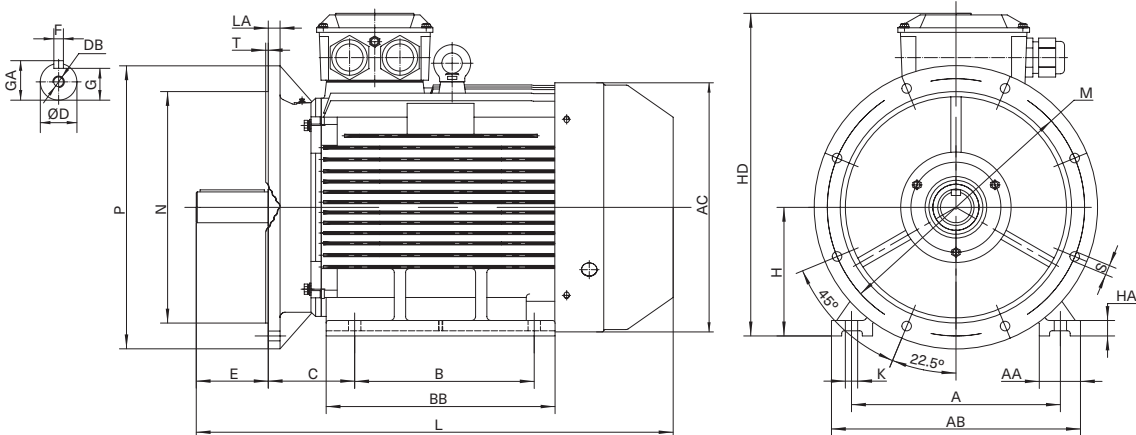

外形图及外形尺寸 / Dimension drawings

机座号 250~280 / Frame Size 250~280

IMB3、IMB6、IMB7、IMB8、IMV5、IMV6 ; IMB35、IMV15、IMV36

机座 Frame Size	转速 Speed r/min	A	AA	AB	AC	B	BB	C	D	DB	E	F	G	GA	H	K	HA	HD	L
250M	3000	406	80	484	485	349	445	168	60	M20	140	18	53	64	250	24	30	640	920
250M	750~1500	406	80	484	485	349	445	168	65	M20	140	18	58	69	250	24	30	640	920
280S	3000	457	85	542	550	368	485	190	65	M20	140	18	58	69	280	24	35	700	980
280S	750~1500	457	85	542	550	368	485	190	75	M20	140	20	67.5	79.5	280	24	35	700	990
280M	3000	457	85	542	550	419	536	190	65	M20	140	18	58	69	280	24	35	700	1030
280ML	3000	457	85	542	550	419	536	190	65	M20	140	18	58	69	280	24	35	700	1070
280M	750~1500	457	85	542	550	419	536	190	75	M20	140	20	67.5	79.5	280	24	35	700	1040
280ML	750~1500	457	85	542	550	419	536	190	75	M20	140	20	67.5	79.5	280	24	35	700	1080

IMB5、IMV1、IMV3 ; IMB35、IMV15、IMV36

机座 Frame Size	转速 Speed r/min	HB	LA	M	N	P	S	T
250M	3000	390	22	500	450	550	18.5	5
250M	750~1500	390	22	500	450	550	18.5	5
280S	3000	420	22	500	450	550	18.5	5
280S	750~1500	420	22	500	450	550	18.5	5
280M	3000	420	22	500	450	550	18.5	5
280ML	3000	420	22	500	450	550	18.5	5
280M	750~1500	420	22	500	450	550	18.5	5
280ML	750~1500	420	22	500	450	550	18.5	5

注：电机立式向下安装时，该电机总长度 L 不包括增加的防雨帽长度。

Note: When the motor is installed vertically downwards, the total length L of the motor does not include the added length of the protective roof.

外形图及外形尺寸 / Dimension drawings

机座号 315~355 / Frame Size 315~355

底脚安装电机 IMB3
Foot-mounted motor IMB3

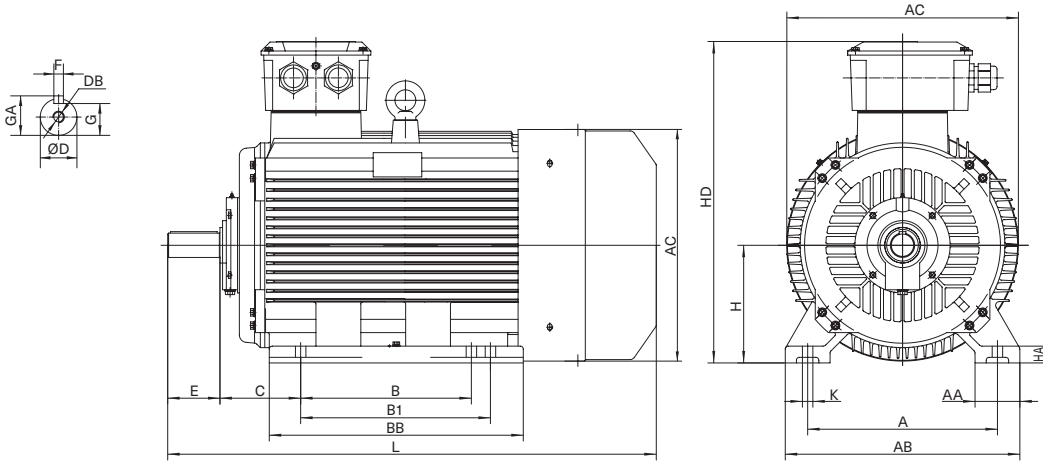

凸缘安装电机 IMV1
Big Flange-mounted motor IMV1

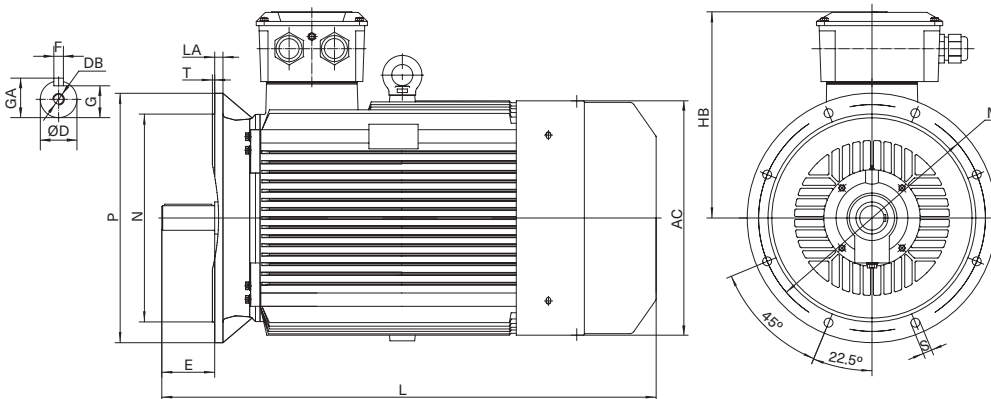

底脚和凸缘安装电机 IMB35、IMV15、IMV36
Foot- and big flange-mounted motor IMB35、IMV15、IMV36

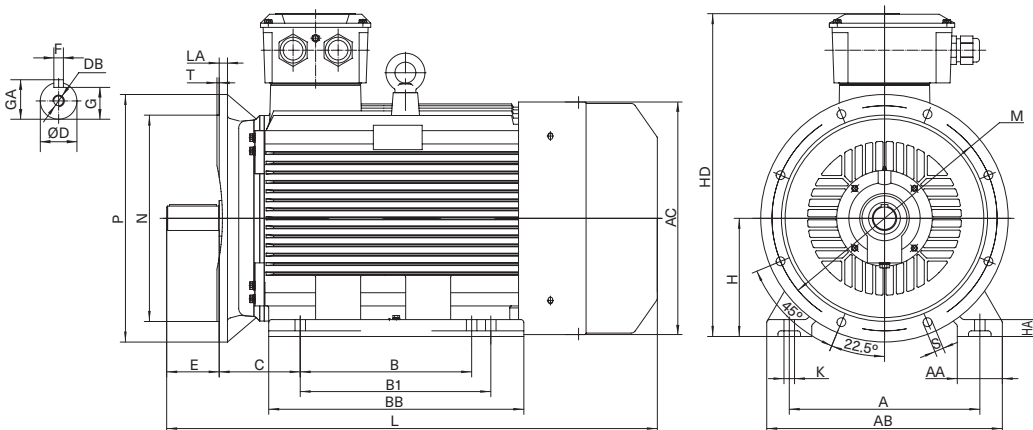

外形图及外形尺寸 / Dimension drawings

机座号 315~355 / Frame Size 315~355

IMB3 ; IMB35、IMV15、IMV36

机座 Frame Size	转速 Speed r/min	A	AA	AB	AC	B	B1	BB	C	D	DB	E	F	G	GA	H	K	HA	HD	L
315S	3000	508	120	628	620	406	-	570	216	65	M20	140	18	58	69	315	28	45	870	1200
315S	750~1500	508	120	628	620	406	-	570	216	80	M20	170	22	71	85	315	28	45	870	1230
315ML	3000	508	120	628	620	457	508	680	216	65	M20	140	18	58	69	315	28	45	870	1310
315ML	750~1500	508	120	628	620	457	508	680	216	80	M20	170	22	71	85	315	28	45	870	1340
355ML	3000	610	116	726	710	560	630	750	254	75	M20	140	20	67.5	79.5	355	28	52	1030	1520
355ML	750~1500	610	116	726	710	560	630	750	254	95	M24	170	25	86	100	355	28	52	1030	1550

IMV1、IMV3 ; IMB35、IMV15、IMV36

机座 Frame Size	转速 Speed r/min	HB	LA	M	N	P	S	T
315S	3000	555	22	600	550	660	24	6
315S	750~1500	555	22	600	550	660	24	6
315ML	3000	555	22	600	550	660	24	6
315ML	750~1500	555	22	600	550	660	24	6
355ML	3000	675	25	740	680	800	24	6
355ML	750~1500	675	25	740	680	800	24	6

注：电机立式向下安装时，该电机总长度 L 不包括增加的防雨帽长度。

Note: When the motor is installed vertically downwards, the total length L of the motor does not include the added length of the protective roof.

挑战自动化的极限，由我们来实现。

We are challengers and push the limits of automation.

我们理解综合自动化的工作原理，其对功能安全有很高要求。但我们会提供简易便捷的解决方案。借助工业4.0的革新，我们会聚焦于产品的基本元素并提升实用价值，以期产品更具人性化，从而更好地服务于客户。

We know how complex automation with high demands on functional safety works. In our case, however, this does not lead to complex solutions. We make use of the possibilities of Industry 4.0 and translate them into customer friendly products and systems that focus on the essentials and have high utility value.

salz-automation.com